

SF2256E

1076.06 MHz SAW Filter

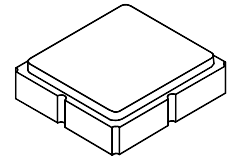

SM3030-8

- **Low-loss SAW Filter**
- **Complies with Directive 2002/95/EC (RoHS)**

Characteristics:

Balanced-to-balanced operation

Terminating source/load impedance : $Z_S = 150 \Omega$



Maximum Rating

Rating	Value	Units
Input Power Level	+10	dBm
DC Voltage on any Non-ground Terminal	3	V
Operating Temperature Range	-40 to +85	°C
Component Storage Temperature Range	-50 to +95	°C
Storage Temperature Range in Tape and Reel	-40 to +85	°C
Suitable for Lead-free Soldering - Maximum Soldering Profile	260°C for 30 s	

Characteristic	Sym	Notes	Min	Typ	Max	Units
Center Frequency	f_C			1076.06		MHz
Minimum Insertion Loss, 1056.06 to 1096.06 MHz	IL_{MIN}			3.1	5.0	dB
2 dB Bandwidth	BW_2		40	52		MHz
Amplitude Ripple, 1056.06 to 1096.06 MHz		2		0.8	2.0	dB
Phase Error, 1056.06 to 1096.06 MHz		2		4.6	6.5	degree
I/O VSWR, 1056.06 to 1096.06 MHz				2.0:1	2.5:1	
Attenuation Referenced to Minimum Insertion Loss:						dB
50 to 994 MHz			42	55		
1158.12 to 1850.00 MHz			42	48		
1850 to 3000 MHz			35	51		
3000 to 6000 MHz			22	26		

Case Style	SM3030-8 3.0 x 3.0 mm Nominal Footprint		
Lid Symbolization (Y=year, WW=week, S=shift) dot=pin 1 indicator	A03, YWWS		
Standard Reel Quantity	Reel Size 7 Inch	500 Pieces/Reel	
	Reel Size 13 Inch	3000 Pieces/Reel	

	Connection	Terminals
Port 1	Balanced Input	1,2
Port 2	Balanced Output	5,6
	Ground	All Others

Dot Indicates Pin 1

SF2256E Test Circuit

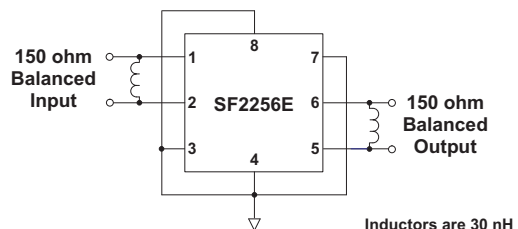

CAUTION: Electrostatic Sensitive Device. Observe precautions for handling.

NOTES:

1. US and international patents may apply.
2. Phase error as measured over any 30 MHz block of the filter's 2 dB bandwidth.
3. Murata, stylized Murata logo, and Murata N.A., Inc. are registered trademarks of Murata Manufacturing Co., Ltd.

Filter Response Plots

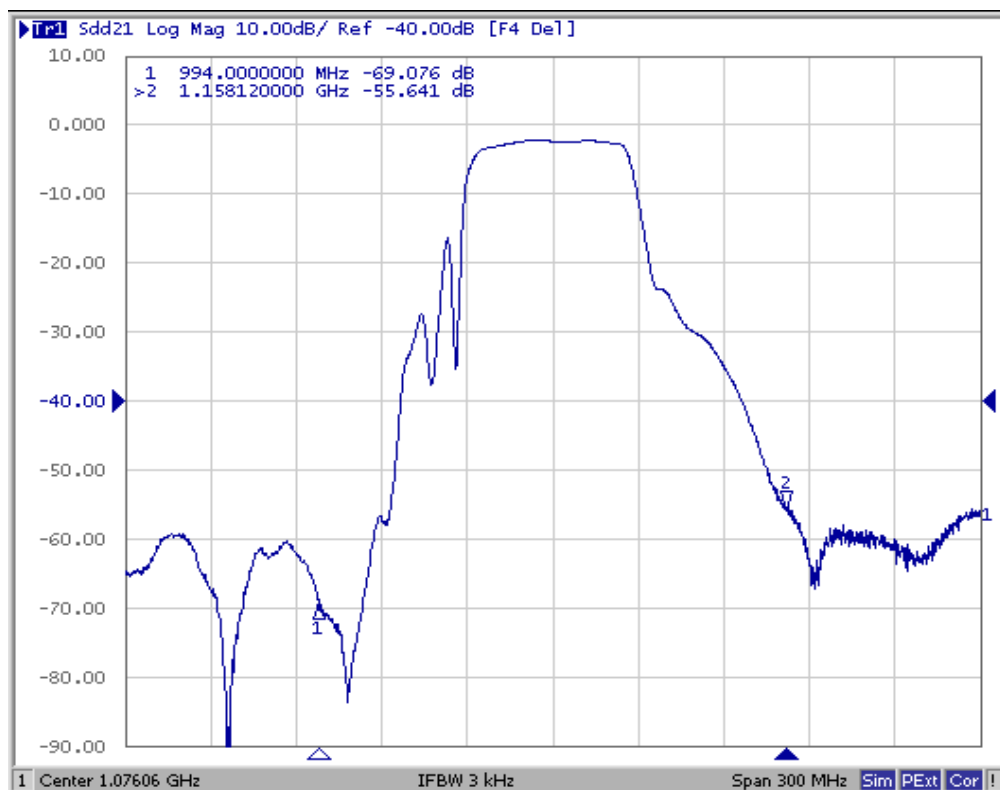
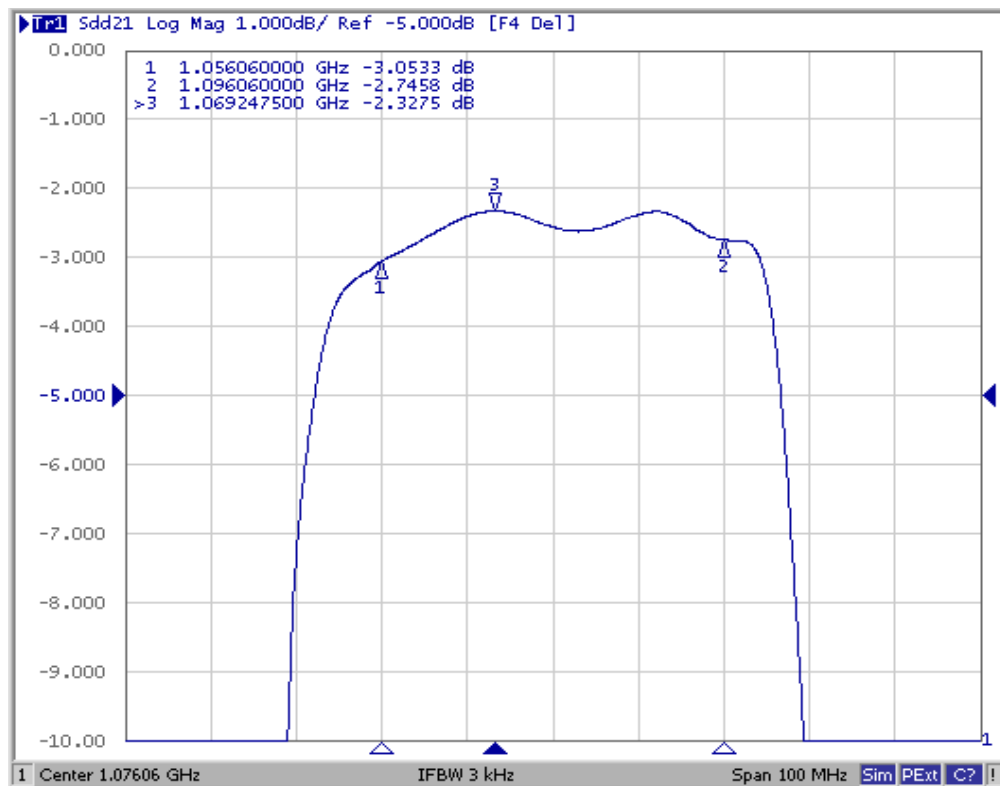

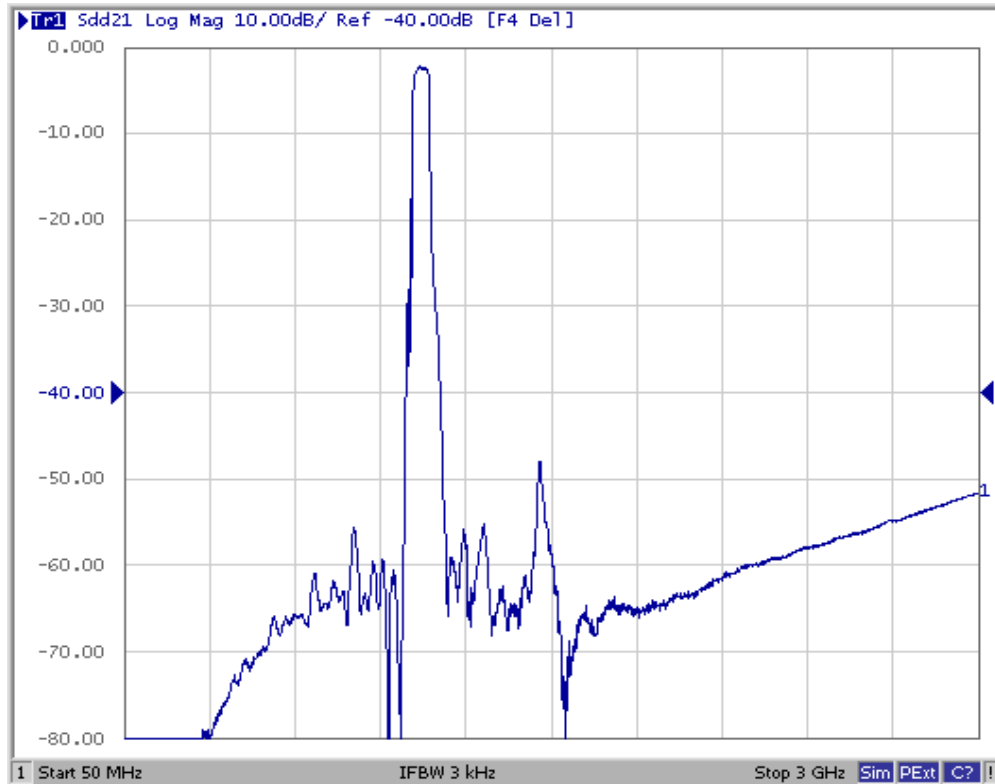

Filter SWR Plots

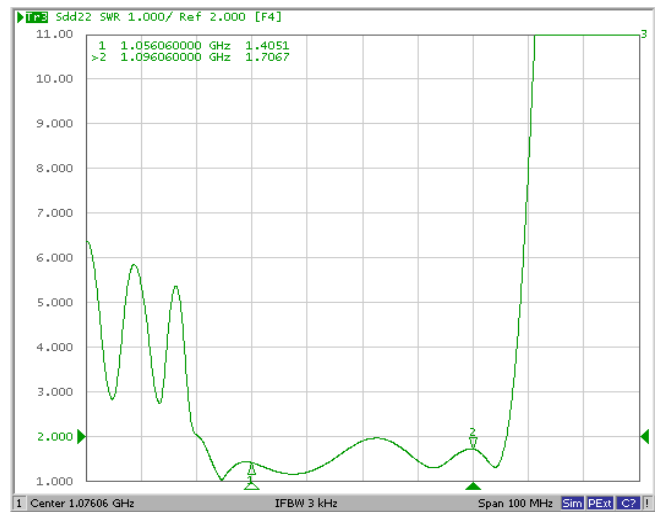
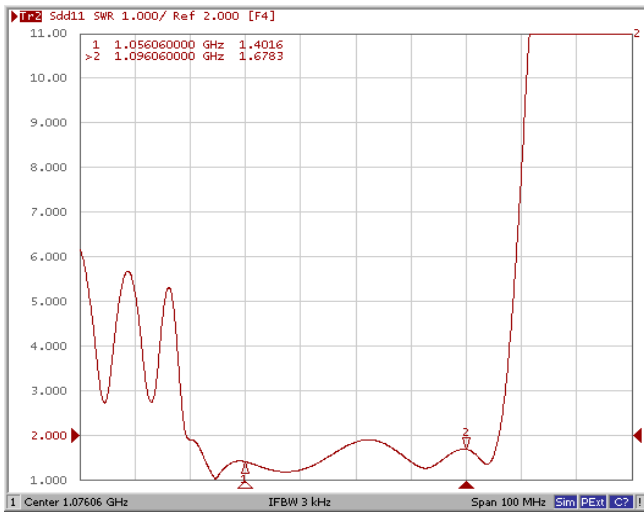

8-Terminal Ceramic Surface-Mount Case 3.0 X 3.0 mm Nominal Footprint

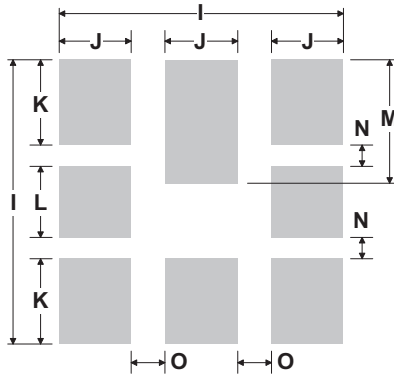
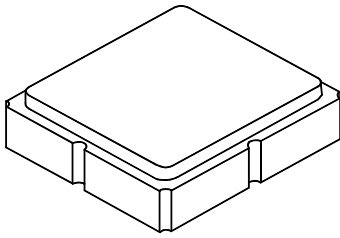

PCB Footprint Top View

Case and PCB Footprint Dimensions

Dimension	mm			Inches		
	Min	Nom	Max	Min	Nom	Max
A	2.87	3.0	3.13	0.113	0.118	0.123
B	2.87	3.0	3.13	0.113	0.118	0.123
C	-	-	1.10	-	-	0.043
D	0.79	0.92	1.05	0.031	0.036	0.041
E	0.62	0.75	0.88	0.024	0.029	0.034
F	0.47	0.60	0.73	0.018	0.024	0.029
G	0.47	0.60	0.73	0.018	0.024	0.029
H	1.07	1.20	1.33	0.042	0.047	0.052
I	-	3.19	-	-	0.126	-
J	-	0.81	-	-	0.032	-
K	-	0.96	-	-	0.038	-
L	-	0.81	-	-	0.032	-
M	-	1.39	-	-	0.055	-
N	-	0.23	-	-	0.009	-
O	-	0.38	-	-	0.015	-

Case Materials

Materials	
Solder Pad Plating	0.3 to 1.0 μm Gold over 1.27 to 8.89 μm Nickel
Lid Plating	2.0 to 3.0 μm Nickel
Body	Al_2O_3 Ceramic
Pb Free	

TOP VIEW

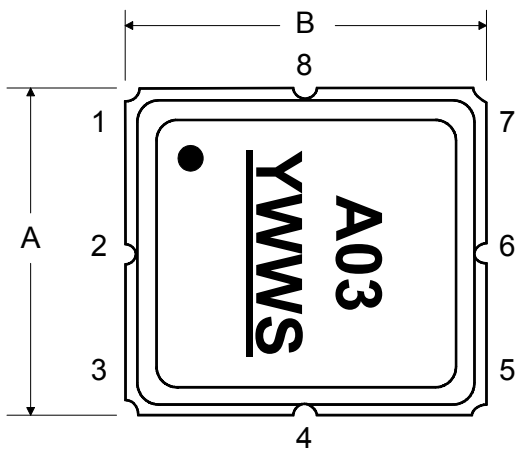

BOTTOM VIEW

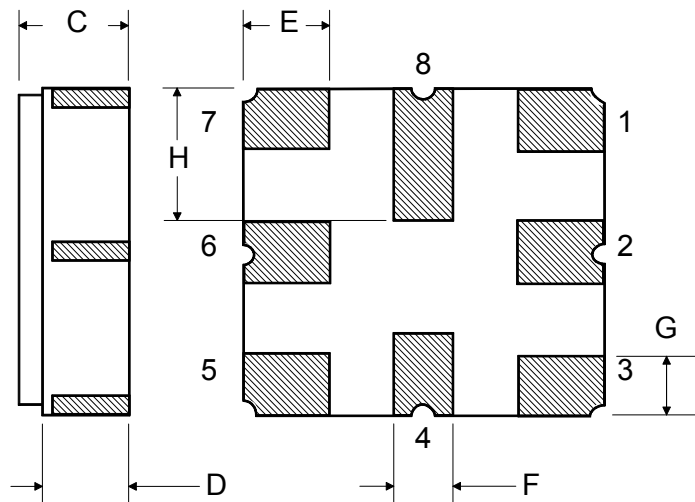

Tape and Reel Specifications

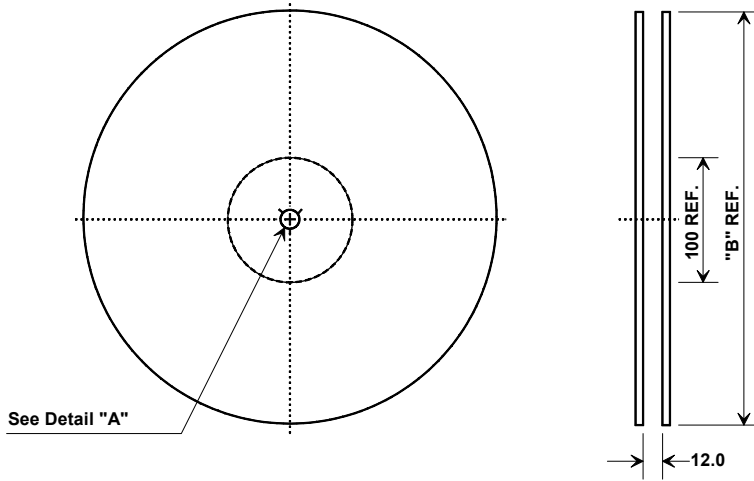

"B"		Quantity Per Reel
Inches	millimeters	
7	178	500
13	330	3000

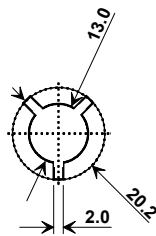

Carrier Tape Dimensions	
Ao	3.35 mm
Bo	3.35 mm
Ko	1.4 mm
Pitch	8.0 mm
W	12.0 mm

COMPONENT ORIENTATION and DIMENSIONS

