

## Features

- 16.5 dB Gain at 900 MHz
- 22 dBm P1dB at 900 MHz
- 40 dBm Output IP3 at 900 MHz
- 6.7 dB NF at 900 MHz
- MTTF > 100 Years
- Single Supply

## Description

The ASW301, a power amplifier MMIC, has a high linearity, high gain, and high efficiency over a wide range of frequency, being suitable for use in both receiver and transmitter of telecommunication systems up to 3 GHz. The amplifier is available in a SOT89 package and passes through the stringent DC, RF, and reliability tests.



Package Style: SOT89

## Typical Performance

(Supply Voltage = +5 V, T<sub>A</sub> = +25 °C, Z<sub>0</sub> = 50 Ω)

Parameters	Units	Typical	
Frequency	MHz	900	2000
Gain	dB	16.5	10.0
S11	dB	-15	-12
S22	dB	-15	-14
Output IP3 <sup>1)</sup>	dBm	40.0	40.5
Noise Figure	dB	6.7	7.0
Output P1dB	dBm	22	22
Current	mA	75	75
Device Voltage	V	+5	+5

1) OIP3 is measured with two tones at an output power of +6 dBm/tone separated by 1 MHz.

## Product Specifications

Parameters	Units	Min	Typ	Max
Testing Frequency	MHz		900	
Gain	dB	16.0	16.5	
S11	dB		-15	
S22	dB		-15	
Output IP3	dBm	39	40	
Noise Figure	dB		6.7	7.0
Output P1dB	dBm	21	22	
Current	mA	70	75	80
Device Voltage	V		+5	

## Absolute Maximum Ratings

Parameters	Rating
Operating Case Temperature	-40 to +85 °C
Storage Temperature	-40 to +150 °C
Device Voltage	+6 V
Operating Junction Temperature	+150 °C
Input RF Power (CW, 50 Ω matched)*	25 dBm

Please find the max. input power data from [http://www.asb.co.kr/pdf/Maximum\\_Input\\_Power\\_Analysis.pdf](http://www.asb.co.kr/pdf/Maximum_Input_Power_Analysis.pdf)

## Application Circuit

- IF
- 500 ~ 2500 MHz

## Pin Configuration

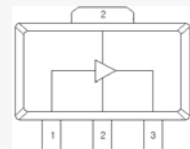

Pin No.	Function
1	RF IN
2	GND
3	RF OUT & Bias

### Outline Drawing

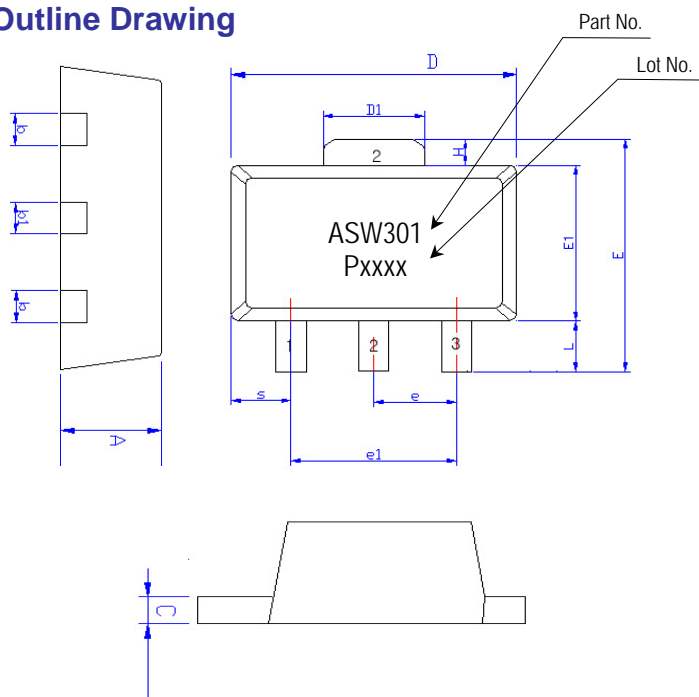

Symbols	Dimensions (In mm)		
	MIN	NOM	MAX
A	1.40	1.50	1.60
L	0.89	1.04	1.20
b	0.36	0.42	0.48
b1	0.41	0.47	0.53
C	0.38	0.40	0.43
D	4.40	4.50	4.60
D1	1.40	1.60	1.75
E	3.64	---	4.25
E1	2.40	2.50	2.60
e1	2.90	3.00	3.10
H	0.35	0.40	0.45
S	0.65	0.75	0.85
e	1.40	1.50	1.60

Pin No.	Function
1	RF IN
2	GND
3	RF OUT & Bias

### Mounting Recommendation (In mm)

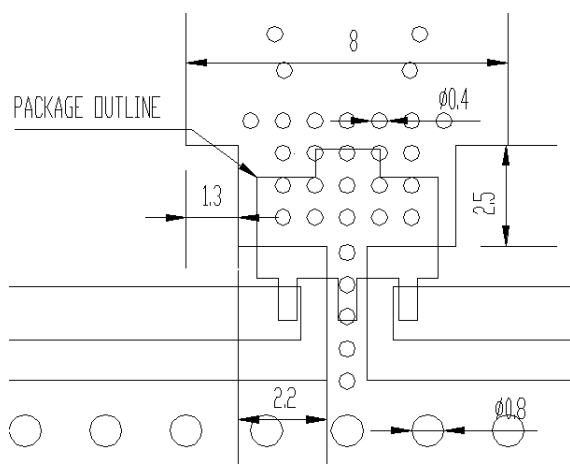

- Note:**
1. The number and size of ground via holes in a circuit board is critical for thermal and RF grounding considerations.
  2. We recommend that the ground via holes be placed on the bottom of the lead pin 2 and exposed pad of the device for better RF and thermal performance, as shown in the drawing at the left side.

### ESD Classification & Moisture Sensitivity Level

#### ESD Classification

HBM	Class 1B
	Voltage Level: 500 V~1000 V
MM	Class A
	Voltage Level: < 200 V

CAUTION: ESD-sensitive device!

#### Moisture Sensitivity Level (MSL)

Level 3 at 260 °C reflow

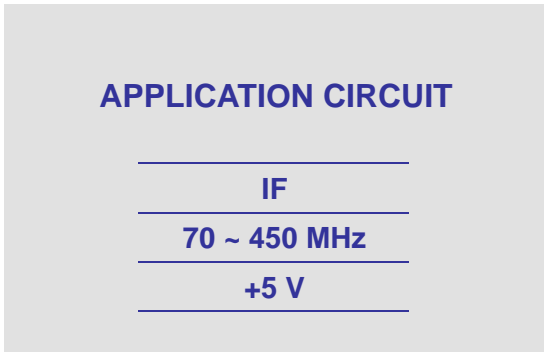

Frequency (MHz)	70	150	300	450
Magnitude S21 (dB)	25	24	23	21
Magnitude S11 (dB)	-9	-14	-15	-15
Magnitude S22 (dB)	-15	-15	-15	-14
Output P1dB (dBm)	22	22	22	22
Output IP3 <sup>1)</sup> (dBm)	35.5	36.0	37.0	37.0
Noise Figure (dB)	6.8	6.8	7.0	6.5
Device Voltage (V)	+5			
Current (mA)	75			

1) OIP3 is measured with two tones at an output power of +8 dBm/tone separated by 1 MHz.

### Schematic

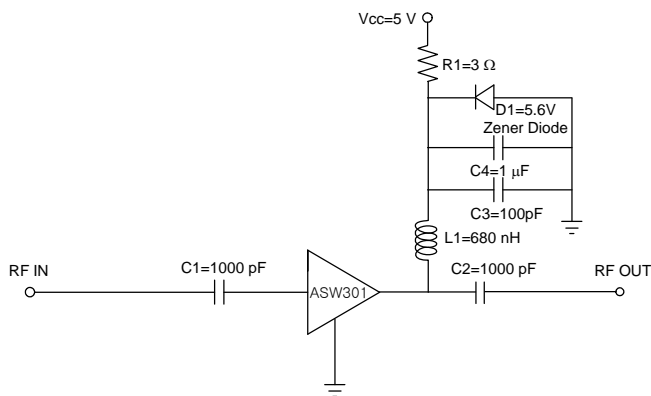

### Board Layout (FR4, 40x40 mm<sup>2</sup>, 0.8T)

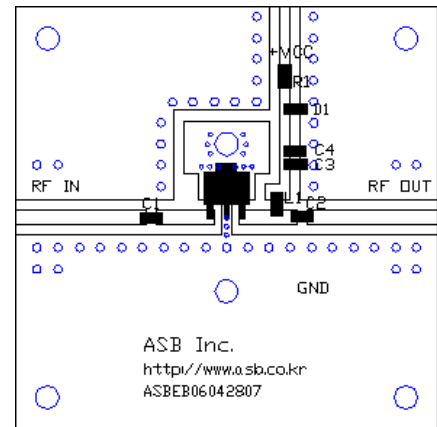

### S-parameters & K-factor

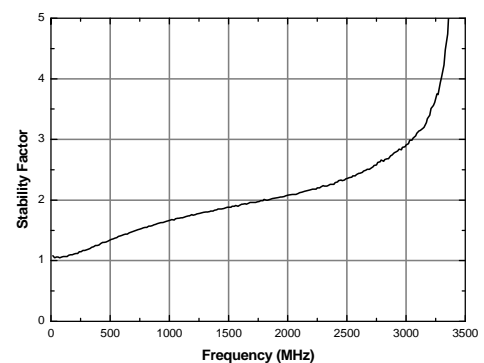
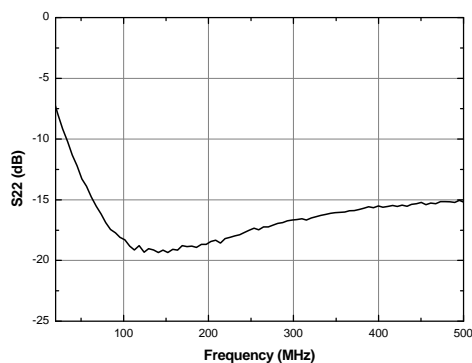
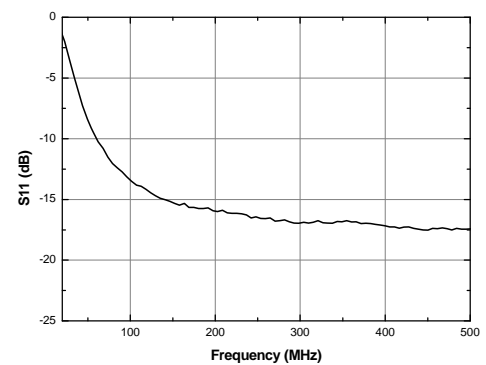
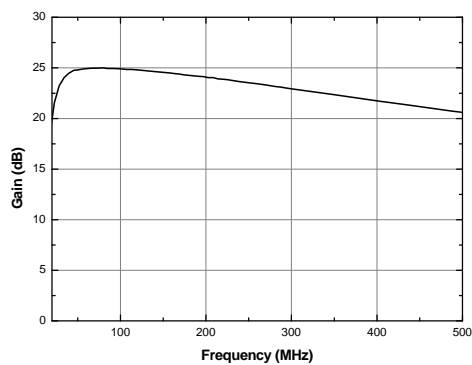

**APPLICATION CIRCUIT**

---

**Wide Band**

---

**500 ~ 2500 MHz**

---

**+5 V**

Frequency (MHz)	500	900	1750	2000	2400
Magnitude S21 (dB)	20.0	16.5	11.0	10.0	8.0
Magnitude S11 (dB)	-13	-15	-14	-12	-11
Magnitude S22 (dB)	-18	-15	-15	-14	-14
Output P1dB (dBm)	22.5	22.0	22.5	22.0	22.0
Output IP3 <sup>1)</sup> (dBm)	38.0	40.0	41.0	40.5	41.0
Noise Figure (dB)	7.0	6.7	7.0	7.0	7.3
Device Voltage (V)	+5				
Current (mA)	75				

1) OIP3 is measured with two tones at an output power of +6 dBm/tone separated by 1 MHz.

### Schematic

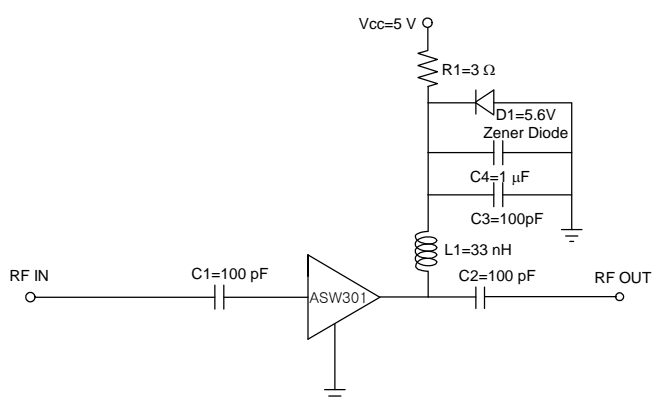

### Board Layout (FR4, 40x40 mm<sup>2</sup>, 0.8T)

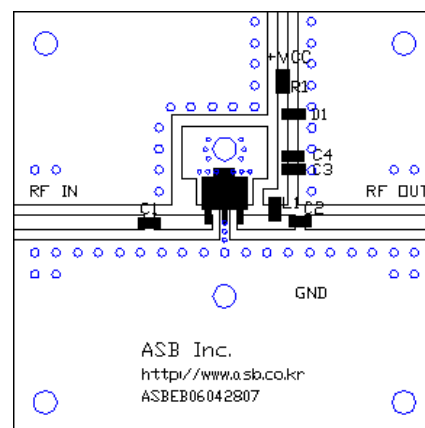

### S-parameters & K-factor

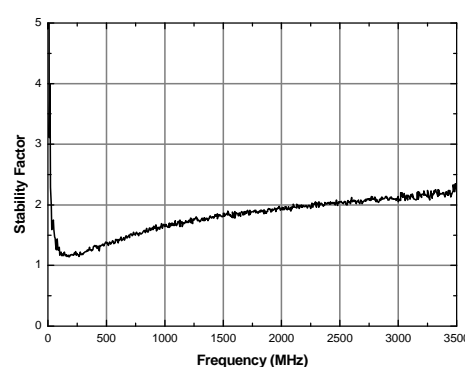
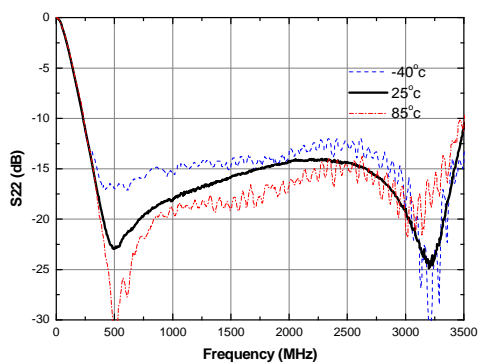
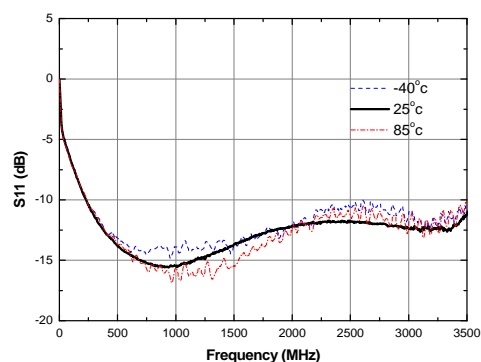
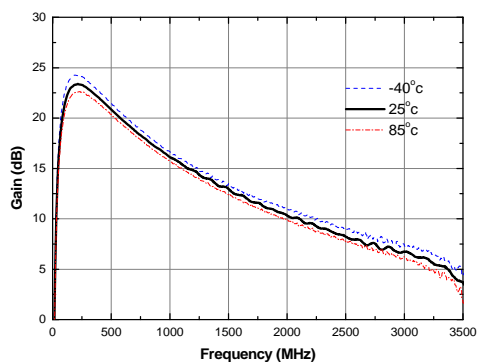

### Current vs. Temperature

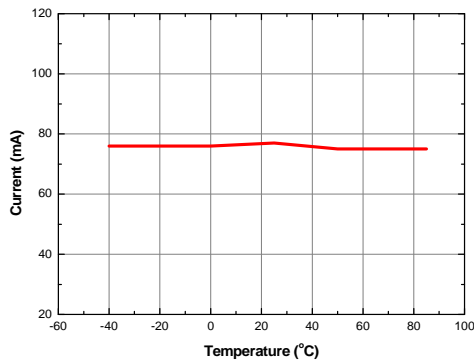

### Gain vs. Temperature

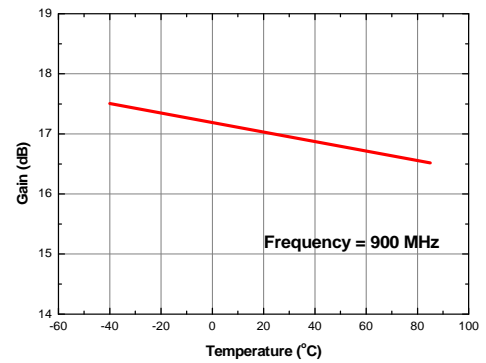

### P1dB vs. Frequency

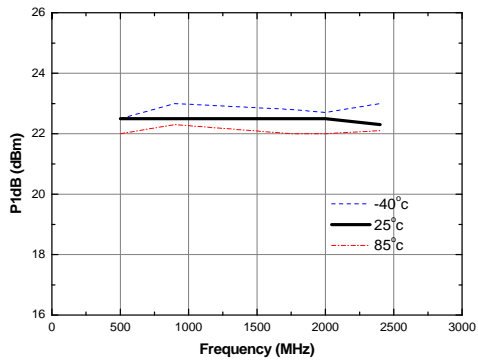

### Output IP3 vs. Frequency

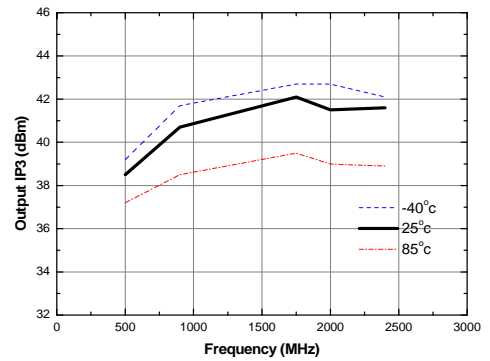

### Output IP3 vs. Tone Power (Frequency = 2000 MHz)

