

Broadband CATV Single Ended 3-Way Active Splitter 50 - 1100 MHz

Rev. V1

Features

- 3-Way Splitter
- Single Ended Input and Outputs
- 4.5 dB and 6 dB Gain Configurations
- Single +5 Volt Supply
- Lead-Free 3 mm 16-Lead PQFN Package
- Halogen-Free “Green” Mold Compound
- RoHS* Compliant and 260°C Reflow Compatible

Description

M/A-COM's MAAM-007239 CATV 3-way active splitter is a GaAs MMIC which exhibits low noise figure and distortion in a lead-free 3mm 16-lead PQFN plastic package. The design employs a low noise, high linearity amplifier and power splitter functionality. The design features 75 Ω inputs and outputs.

The MAAM-007239 is ideally suited for multi-tuner set top boxes, home gateways, and other broadband internet based appliances.

The MAAM-007239 is fabricated using M/A-COM's PHEMT process to realize low noise and low distortion. The process features full passivation for robust performance and reliability.

Ordering Information ^{1,2}

| Part Number | Package |
|--------------------|------------------------------|
| MAAM-007239-TR1000 | 1000 piece reel |
| MAAM-007239-TR3000 | 3000 piece reel |
| MAAM-007239-001SMB | High Isolation Configuration |
| MAAM-007239-002SMB | Low Current Configuration |

1. Reference Application Note M513 for reel size information.
2. All sample boards include 5 loose parts.

Functional Schematic

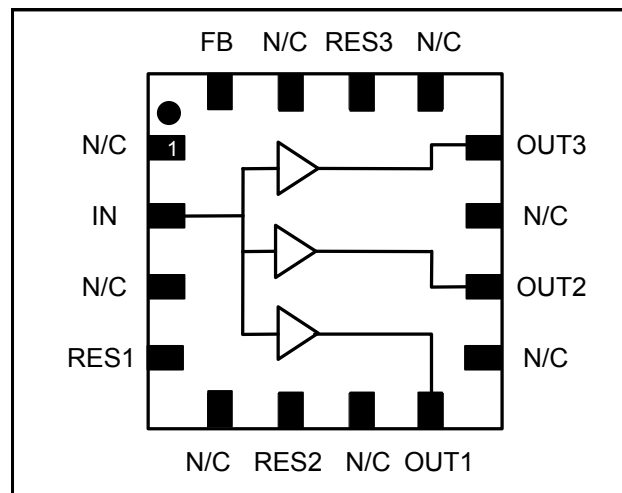

Pin Configuration

| Pin No. | Pin Name | Description |
|---------|---------------------|------------------|
| 1 | N/C | No Connection |
| 2 | IN | RF Input |
| 3 | N/C | No Connection |
| 4 | RES1 | Resistor 1 |
| 5 | N/C | No Connection |
| 6 | RES2 | Resistor 2 |
| 7 | N/C | No Connection |
| 8 | OUT1 | RF Output 1 |
| 9 | N/C | No Connection |
| 10 | OUT2 | RF Output 2 |
| 11 | N/C | No Connection |
| 12 | OUT3 | RF Output 3 |
| 13 | N/C | No Connection |
| 14 | RES3 | Resistor 3 |
| 15 | N/C | No Connection |
| 16 | FB | Feedback |
| 17 | Paddle ³ | RF and DC Ground |

3. The exposed pad centered on the package bottom must be connected to RF and DC ground.

* Restrictions on Hazardous Substances, European Union Directive 2002/95/EC.

Broadband CATV Single Ended 3-Way Active Splitter 50 - 1100 MHz

Rev. V1

Low Current Configuration

Electrical Specifications: $F = 50 - 1000 \text{ MHz}$, $T_A = 25^\circ \text{ C}$, $V_{DD} = +5 \text{ Volts}$, $Z_0 = 75 \Omega$

| Parameter | Test Conditions | Units | Min. | Typ. | Max. |
|-----------------------------|---|-------|------|------|------|
| Gain | IN to OUT1, IN to OUT2, IN to OUT3 | dB | 5.0 | 6.0 | 7.0 |
| Gain Flatness | IN to OUT1, IN to OUT2, IN to OUT3 | dB | - | 1.0 | 1.8 |
| Noise Figure | IN to OUT1, IN to OUT2, IN to OUT3 | dB | - | 4.5 | 5.0 |
| Input Return Loss | IN | dB | - | 15 | - |
| Output Return Loss | OUT1, OUT2, OUT3 | dB | - | 20 | - |
| Composite Triple Beat, CTB | 132 channels, +15 dBmV/channel at the input | dBc | - | -77 | -70 |
| Composite Second Order, CSO | 132 channels, +15 dBmV/channel at the input | dBc | - | -65 | -56 |
| Crossmodulation, XMOD | 132 channels, +15 dBmV/channel at the input | dBc | - | -65 | - |
| Reverse Isolation | OUT1 to IN, OUT2 to IN, OUT3 to IN | dB | - | 23 | - |
| Output to Output Isolation | OUT1 to OUT2 or OUT3 | dB | - | 22 | - |
| P1dB | 400 MHz | dBm | - | 17 | - |
| OIP3 | 50 MHz / 1 GHz Two Tones at 6 MHz Spacing, $P_{IN} = -10 \text{ dBm}$ per Tone | dBm | - | 23 | - |
| OIP2 | 50 MHz / 1 GHz Two Tones at 6 MHz Spacing, $P_{IN} = -10 \text{ dBm}$ per Tone | dBm | - | 48 | - |
| I_{DD} | $V_{DD} = +5 \text{ Volts}$ | mA | - | 125 | 150 |

High Isolation Configuration

Typical Performance: $F = 50 - 1000 \text{ MHz}$, $T_A = 25^\circ \text{ C}$, $V_{DD} = +5 \text{ Volts}$, $Z_0 = 75 \Omega$

| Parameter | Test Conditions | Units | Min. | Typ. | Max. |
|-----------------------------|---|-------|------|------|------|
| Gain | IN to OUT1, IN to OUT2, IN to OUT3 | dB | - | 4.6 | - |
| Gain Flatness | IN to OUT1, IN to OUT2, IN to OUT3 | dB | - | 0.8 | - |
| Noise Figure | IN to OUT1, IN to OUT2, IN to OUT3 | dB | - | 4.5 | - |
| Input Return Loss | IN | dB | - | 17 | - |
| Output Return Loss | OUT1, OUT2, OUT3 | dB | - | 12 | - |
| Composite Triple Beat, CTB | 132 channels, +15 dBmV/channel at the input | dBc | - | -83 | - |
| Composite Second Order, CSO | 132 channels, +15 dBmV/channel at the input | dBc | - | -70 | - |
| Crossmodulation, XMOD | 132 channels, +15 dBmV/channel at the input | dBc | - | -65 | - |
| Reverse Isolation | OUT1 to IN, OUT2 to IN, OUT3 to IN | dB | - | 25 | - |
| Output to Output Isolation | OUT1 to OUT2 or OUT3 | dB | - | 32 | - |
| P1dB | 400 MHz | dBm | - | 19 | - |
| OIP3 | 50 MHz / 1 GHz Two Tones at 6 MHz Spacing, $P_{IN} = -10 \text{ dBm}$ per Tone | dBm | - | 27 | - |
| OIP2 | 50 MHz / 1 GHz Two Tones at 6 MHz Spacing, $P_{IN} = -10 \text{ dBm}$ per Tone | dBm | - | 52 | - |
| I_{DD} | $V_{DD} = +5 \text{ Volts}$ | mA | - | 210 | - |

Recommended PCB configuration
Low Current Configuration

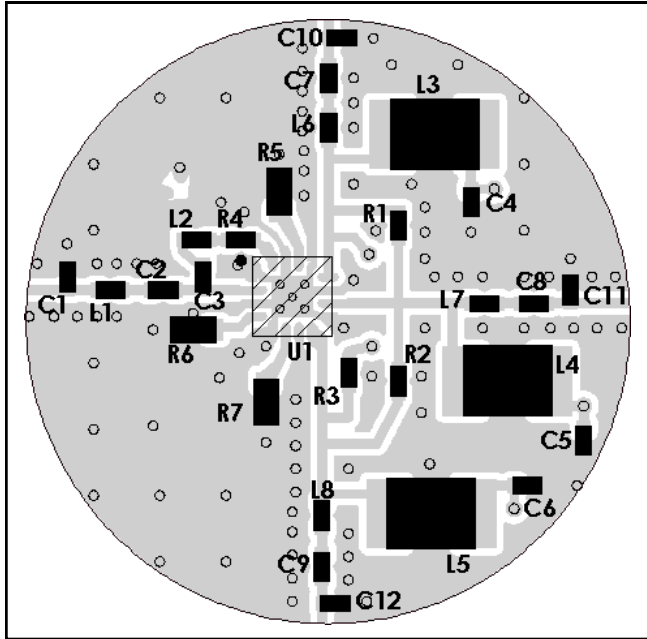

Off-Chip Component Values⁴
Low Current Configuration

| Component | Value | Package |
|-----------|--------------|---------|
| C1 | 1 pF | 0402 |
| C2 - C9 | 0.01 μ F | 0402 |
| C10 - C12 | 0.5 pF | 0402 |
| L1, L2 | 11 nH | 0402 |
| L3 - L5 | 1 μ H | 1210 |
| L6 - L8 | 12 nH | 0402 |
| R1 - R3 | 620 Ω | 0402 |
| R4 | 68 Ω | 0402 |
| R5 - R7 | 18 Ω | 0603 |

4. L3 - L5 supplied from EPCOS, part number B82422A1102K100

Schematic Including Off-Chip Components
Low Current Configuration

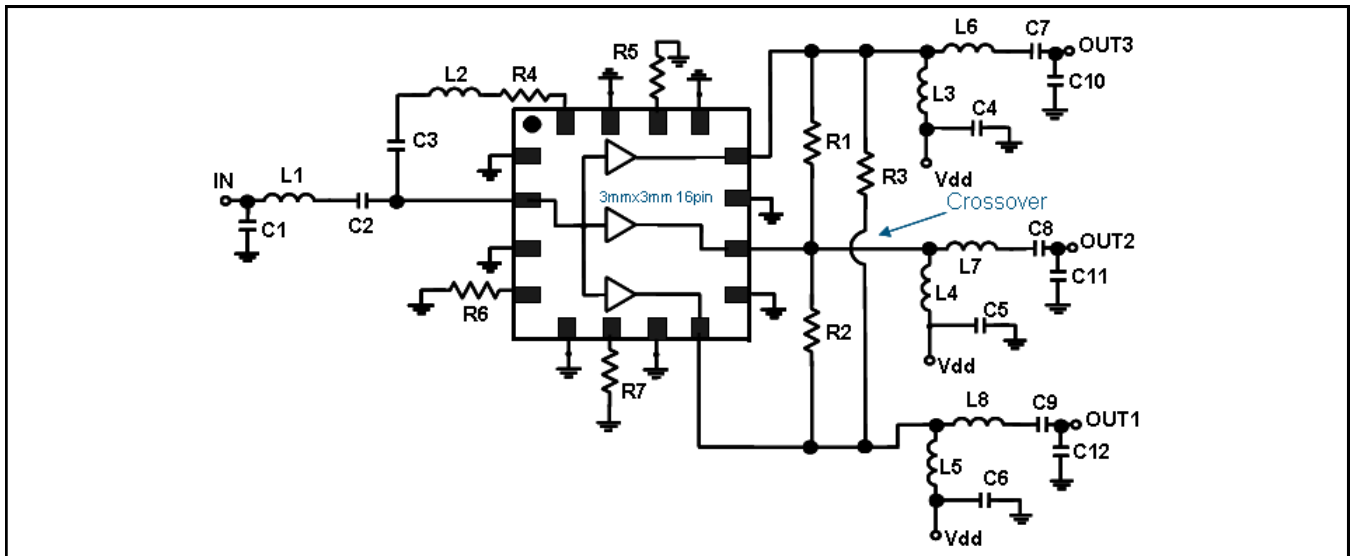

Broadband CATV Single Ended 3-Way Active Splitter 50 - 1100 MHz

Rev. V1

Absolute Maximum Ratings ^{5,6,7}

| Parameter | Absolute Maximum |
|-----------------------------------|------------------|
| Max Input Power | +12 dBm |
| Vbias | +10.0 V |
| Operating Temperature | -40°C to +85°C |
| Junction Temperature ⁸ | 150°C |
| Storage Temperature | -65°C to +125°C |

- Exceeding any one or combination of these limits may cause permanent damage to this device.
- M/A-COM does not recommend sustained operation near these survivability limits.
- These operating conditions will ensure MTTF > 1 x 10⁶ hours.
- Junction Temperature (T_J) = T_C + (Θ_{JC}) * (V*I)
Typical thermal resistance (Θ_{JC}) = 42° C/W.
 - For T_C = 25°C,
(Low Current Configuration) T_J = 51 °C @ 5 V, 125 mA
(High Current Configuration) T_J = 69 °C @ 5 V, 210 mA
 - For T_C = 85°C,
(Low Current Configuration) T_J = 111 °C @ 5 V, 125 mA
(High Current Configuration) T_J = 129 °C @ 5 V, 210 mA

Handling Procedures

Please observe the following precautions to avoid damage:

Static Sensitivity

Gallium Arsenide Integrated Circuits are sensitive to electrostatic discharge (ESD) and can be damaged by static electricity. Proper ESD control techniques should be used when handling these devices.

Lead-Free 3 mm 16-Lead PQFN[†]

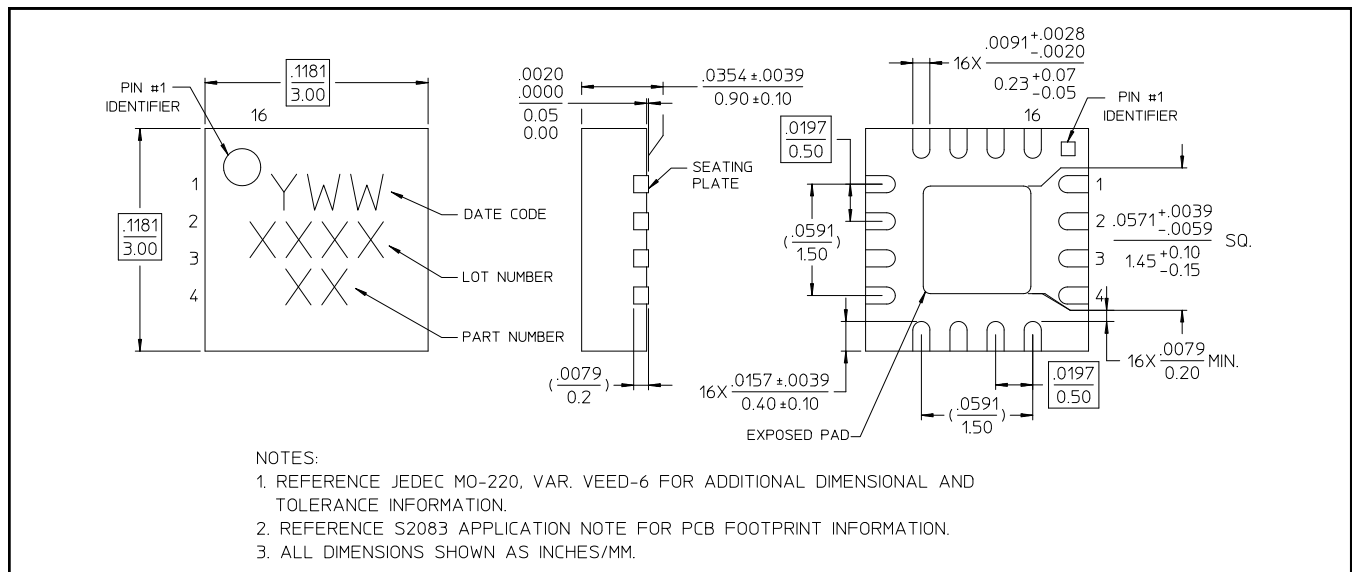

[†] Reference Application Note S2083 for lead-free solder reflow recommendations.
Meets JEDEC moisture sensitivity level 1 requirements.
Plating is 100% matte tin over copper.

Broadband CATV Single Ended 3-Way Active Splitter 50 - 1100 MHz

Rev. V1

Typical Performance Curves: Low Current Configuration

Gain - OUT1

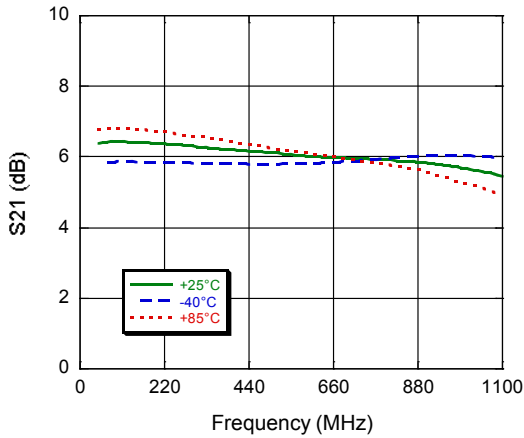

Gain - OUT2

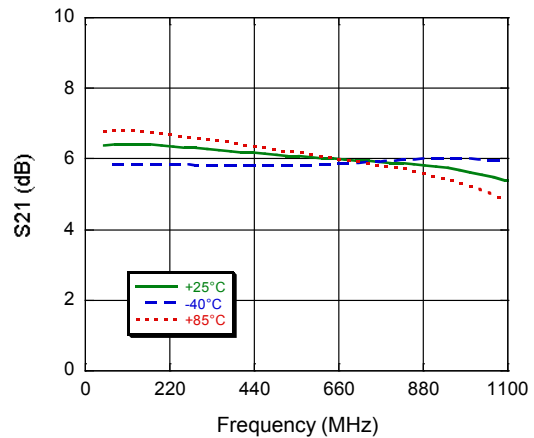

Gain - OUT3

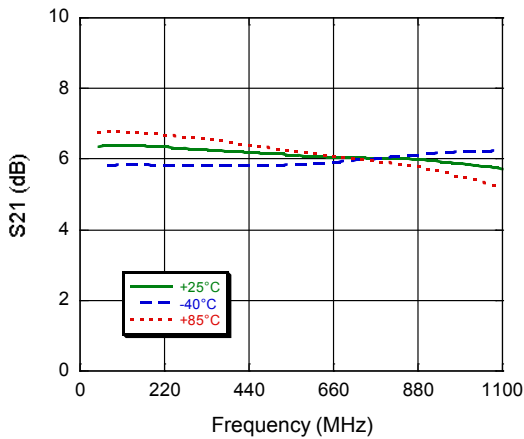

Gain - typical all ports - to 3 GHz

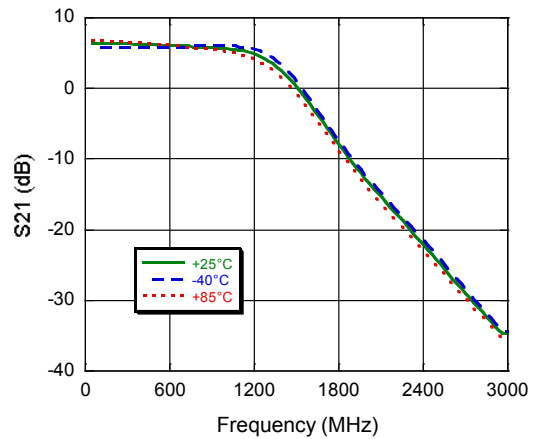

Input Return Loss

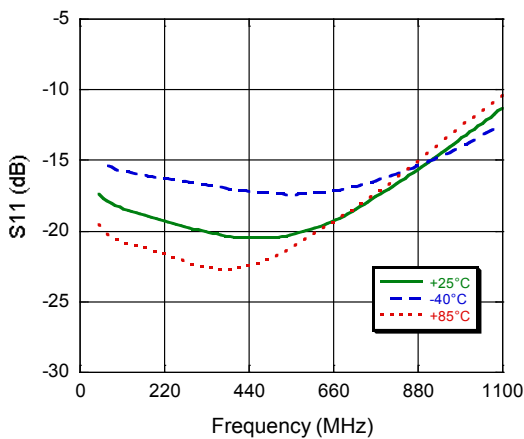

Out1 - Return Loss

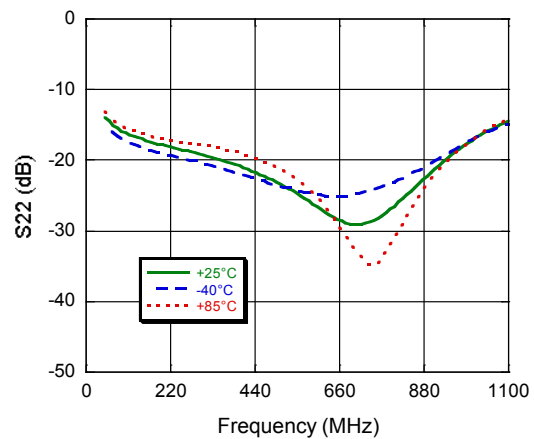

Broadband CATV Single Ended 3-Way Active Splitter 50 - 1100 MHz

Rev. V1

Typical Performance Curves: Low Current Configuration

Out2 - Return Loss

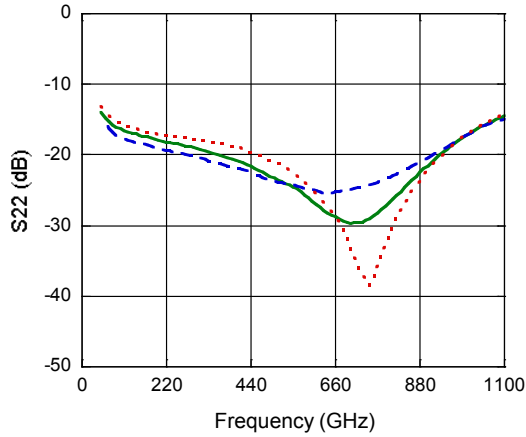

Out3 - Return Loss

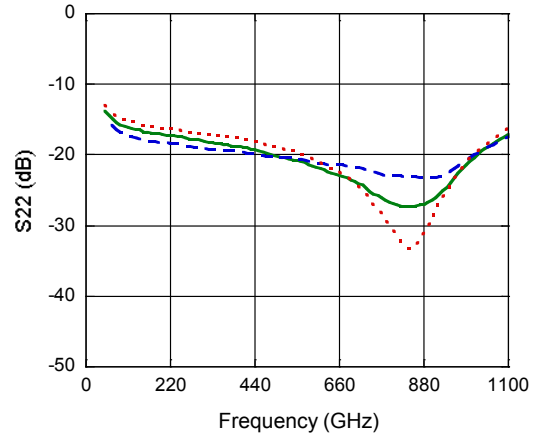

Reverse Isolation

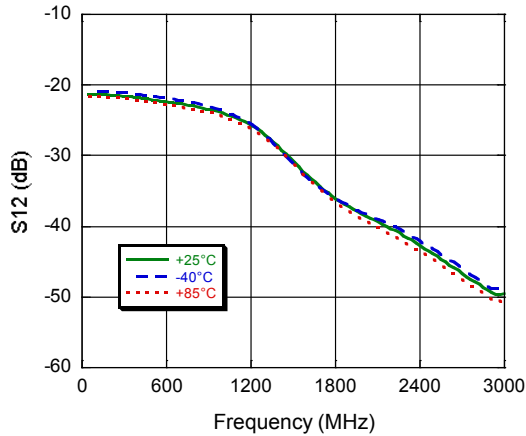

OUT - OUT Isolation - to 1 GHz

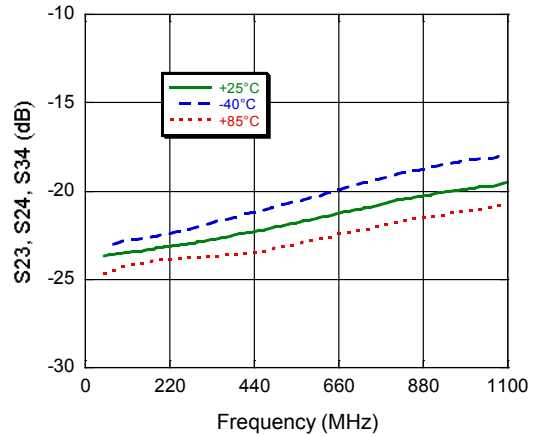

OUT - OUT Isolation - to 3 GHz

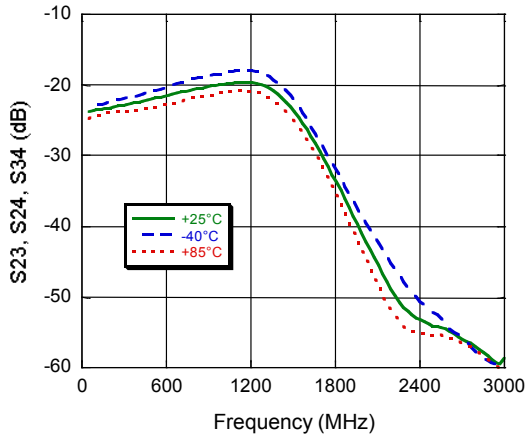

Noise Figure - Typical for all ports

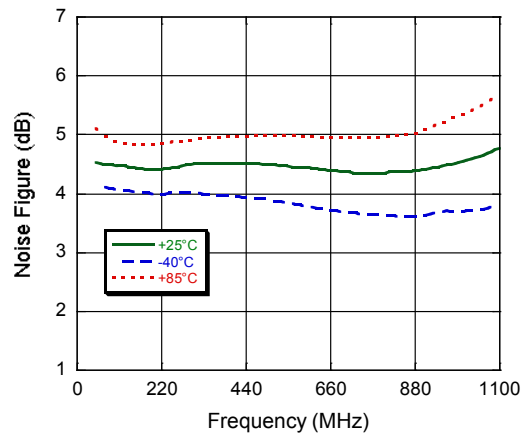

Broadband CATV Single Ended 3-Way Active Splitter 50 - 1100 MHz

Rev. V1

Recommended PCB configuration High Isolation Configuration

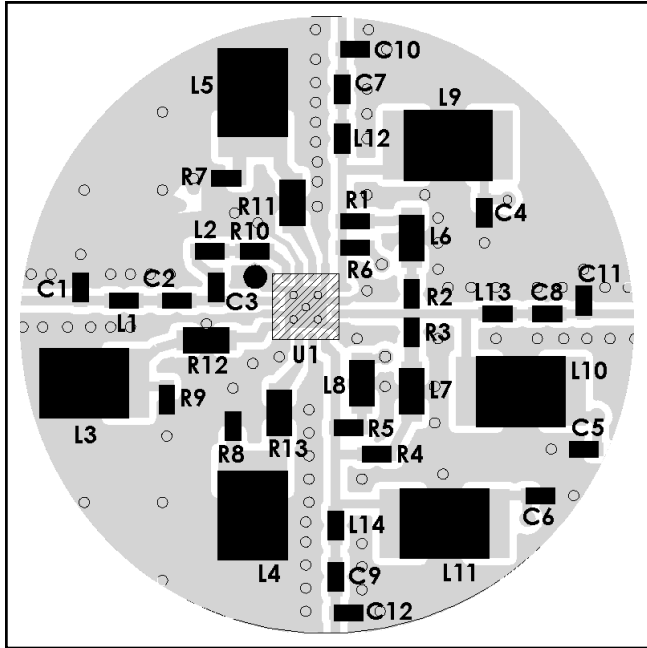

Off-Chip Component Values⁹ High Isolation Configuration

| Component | Value | Package |
|-------------------|--------------|---------|
| C1 | 1 pF | 0402 |
| C2 - C9 | 0.01 μ F | 0402 |
| C10 - C12 | 0.5 pF | 0402 |
| L1 | 11 nH | 0402 |
| L2 | 19 nH | 0402 |
| L3 - L5, L9 - L11 | 1 μ H | 1210 |
| L6 | 100 nH | 0603 |
| L7 | 110 nH | 0603 |
| L8 | 82 nH | 0603 |
| L12 - L14 | 12 nH | 0402 |
| R1 - R6 | 270 Ω | 0402 |
| R7 - R9 | 22 Ω | 0402 |
| R10 | 100 Ω | 0402 |
| R11 - R13 | 8.2 Ω | 0603 |

9. L3 - L5 and L9 - L11 supplied from EPCOS, part number B82422A1102K100.

Schematic Including Off-Chip Components High Isolation Configuration

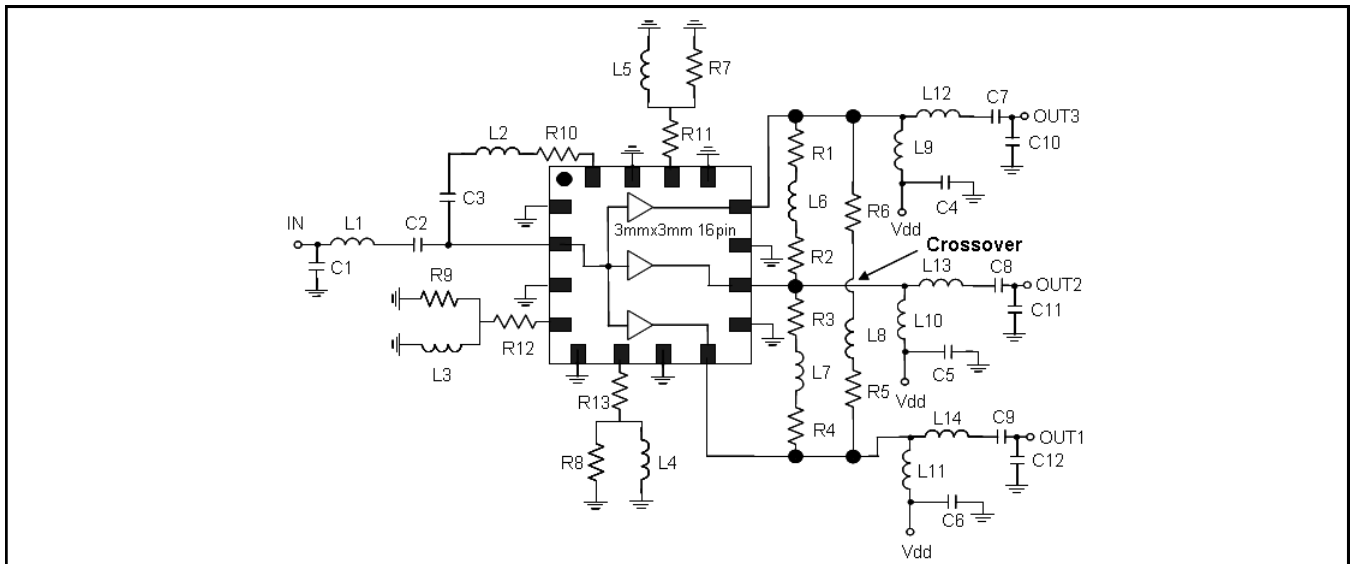

Broadband CATV Single Ended 3-Way Active Splitter 50 - 1100 MHz

Rev. V1

Typical Performance Curves: High Isolation Configuration

Gain - OUT1

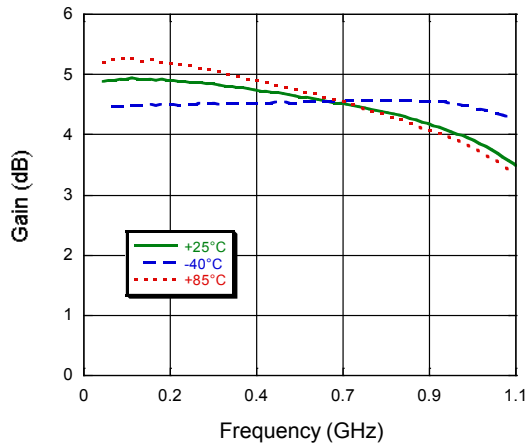

Gain - OUT2

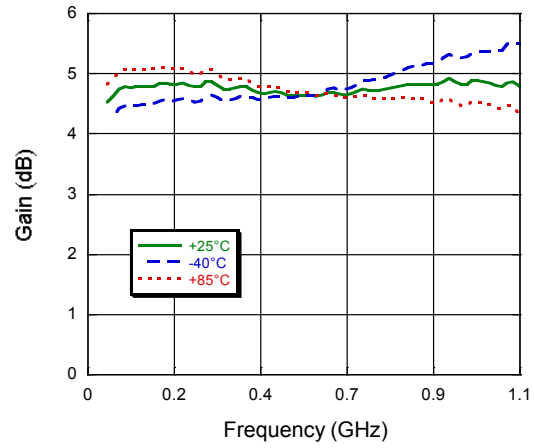

Gain - OUT3

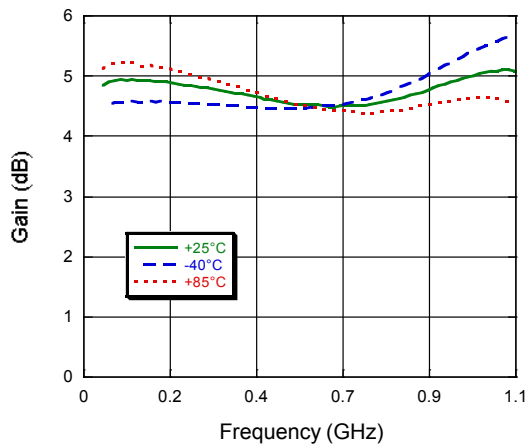

Gain - typical all ports - to 3 GHz

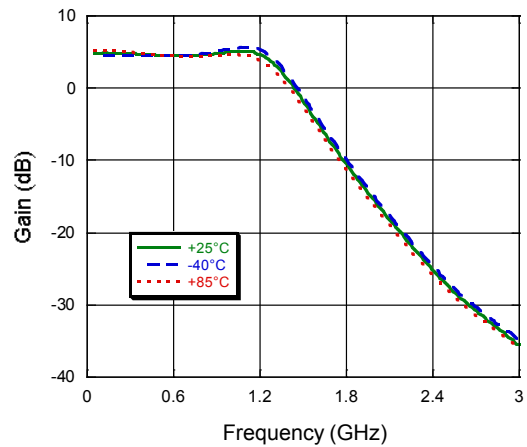

Input Return Loss

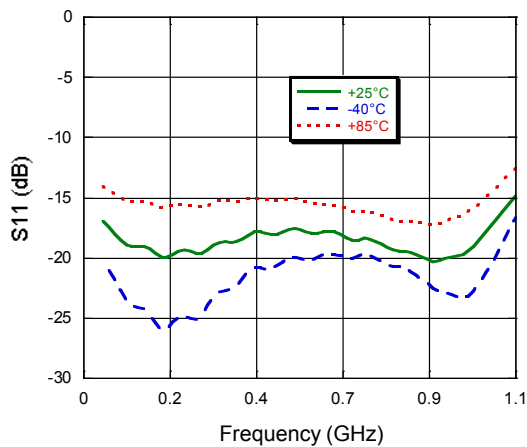

Out1 - Return Loss

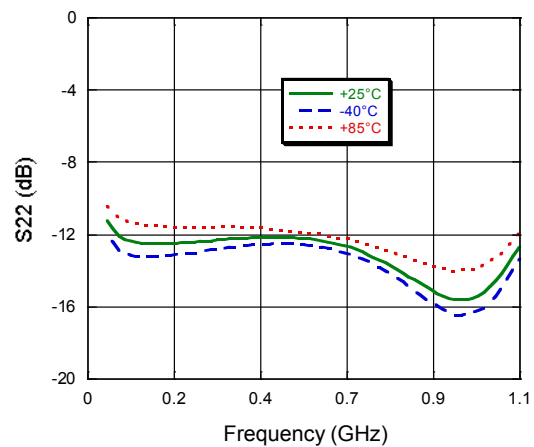

Broadband CATV Single Ended 3-Way Active Splitter 50 - 1100 MHz

Rev. V1

Typical Performance Curves: High Isolation Configuration

OUT2 - Return Loss

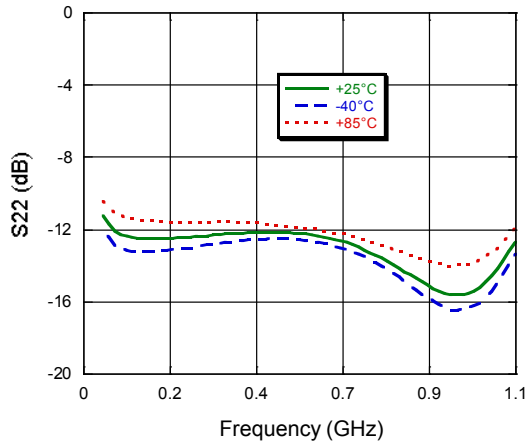

OUT3 - Return Loss

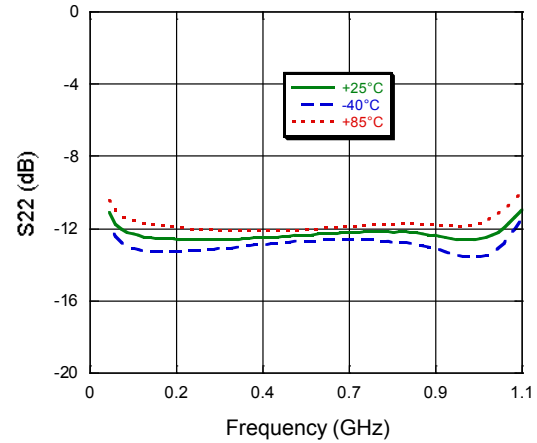

Noise Figure - Typical for all ports

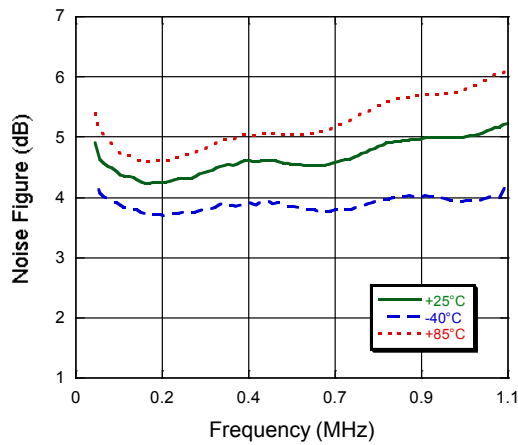

OUT1 - OUT2 Isolation

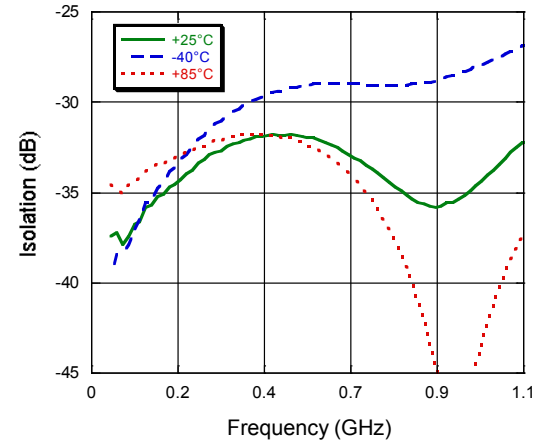

OUT1 - OUT3 Isolation

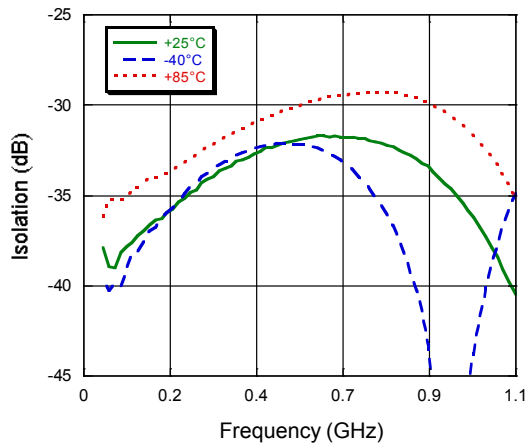

OUT2 - OUT3 Isolation

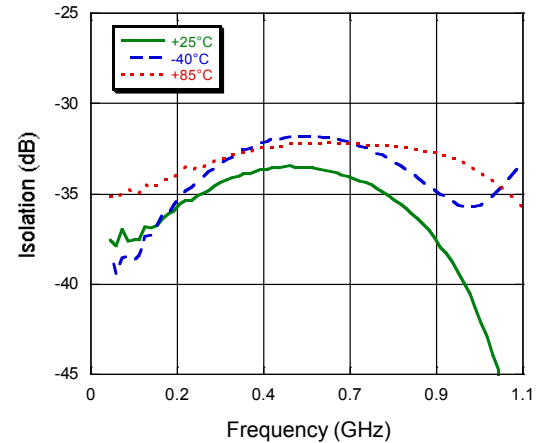

M/A-COM Technology Solutions Inc. All rights reserved.

Information in this document is provided in connection with M/A-COM Technology Solutions Inc ("MACOM") products. These materials are provided by MACOM as a service to its customers and may be used for informational purposes only. Except as provided in MACOM's Terms and Conditions of Sale for such products or in any separate agreement related to this document, MACOM assumes no liability whatsoever. MACOM assumes no responsibility for errors or omissions in these materials. MACOM may make changes to specifications and product descriptions at any time, without notice. MACOM makes no commitment to update the information and shall have no responsibility whatsoever for conflicts or incompatibilities arising from future changes to its specifications and product descriptions. No license, express or implied, by estoppel or otherwise, to any intellectual property rights is granted by this document.

THESE MATERIALS ARE PROVIDED "AS IS" WITHOUT WARRANTY OF ANY KIND, EITHER EXPRESS OR IMPLIED, RELATING TO SALE AND/OR USE OF MACOM PRODUCTS INCLUDING LIABILITY OR WARRANTIES RELATING TO FITNESS FOR A PARTICULAR PURPOSE, CONSEQUENTIAL OR INCIDENTAL DAMAGES, MERCHANTABILITY, OR INFRINGEMENT OF ANY PATENT, COPYRIGHT OR OTHER INTELLECTUAL PROPERTY RIGHT. MACOM FURTHER DOES NOT WARRANT THE ACCURACY OR COMPLETENESS OF THE INFORMATION, TEXT, GRAPHICS OR OTHER ITEMS CONTAINED WITHIN THESE MATERIALS. MACOM SHALL NOT BE LIABLE FOR ANY SPECIAL, INDIRECT, INCIDENTAL, OR CONSEQUENTIAL DAMAGES, INCLUDING WITHOUT LIMITATION, LOST REVENUES OR LOST PROFITS, WHICH MAY RESULT FROM THE USE OF THESE MATERIALS.

MACOM products are not intended for use in medical, lifesaving or life sustaining applications. MACOM customers using or selling MACOM products for use in such applications do so at their own risk and agree to fully indemnify MACOM for any damages resulting from such improper use or sale.