

Xtra Long Life 100 million cycles

USB/Ethernet RF Switch Matrix RC-2SP4T-A18

50Ω DC to 18 GHz

The Big Deal

- **USB or Ethernet-TCP/IP** (HTTP and Telnet protocols) control
- Capable of 100 million cycles
- Two SP4T electromechanical, absorptive RF switches (85 dB typ. isolation)
- Plug-and-Play usable with Windows®, Mac®, and Linux® computers



Case Style: MR1937



Installation CD

Product Overview

Mini-Circuits' RC-2SP4T-A18 is a general purpose RF switch matrix controlled via either USB or Ethernet-TCP/IP (supports HTTP and Telnet protocols). The model contains two electromechanical SP4Ts, absorptive fail-safe RF switches constructed in break-before-make configuration and powered by +24VDC with switching time of 25 ms typical. The RF switches can be operated remotely using the supplied GUI software or programmed by the user with the included API objects. The RF switches operates over a wide frequency band from DC to 18 GHz, have low insertion loss (0.2 dB typical) and high isolation (85 dB typical) making the switch matrix perfectly suitable for a wide variety of RF applications.

The RC-2SP4T-A18 is constructed in a compact, rugged metal case (5.5" x 6.0" x 2.25") with 10 SMA(F) connectors (COM, 1, 2, 3, and 4 for each switch), a 2.1mm DC socket, USB type B port, and a standard RJ45 network socket. The model is supplied with our easy-to-install, easy-to-use GUI software and API objects for Windows environments with complete programming instructions for 32 and 64 bit Windows® and Linux® operating systems. Also included is a 2.7 ft. USB cable, a 5 ft. Ethernet cable for Ethernet (HTTP and Telnet) control, and a power adaptor suitable for US, EU, and other power systems. See page 9 for list of all accessories included. Longer USB cables and a mounting bracket are available as additional accessories.

Key Features

Feature	Advantages
Ethernet-TCP/IP- HTTP and Telnet Protocols (Supports DHCP and Static IP)	The RC-2SP4T-A18 switch matrix can be controlled from any Windows®, Mac®, or Linux® computer, or even a mobile device with a network connection and Ethernet-TCP/IP (HTTP or Telnet protocols) support. Using a VPN would allow remote control from anywhere in the world.
USB HID (Human Interface Device)	User may also control the switch matrix via USB connection. Plug-and-Play, no driver required. Compatible with Windows® or Linux® operating systems using 32 and 64 bit architecture.
RF SP4T absorptive electromechanical switches	Wideband (DC to 18 GHz) with low insertion loss (0.2 dB typ.), very high isolation (85 dB typ.), and high power rating (2W Hot switching).
24VDC operating voltage	The RC-2SP4T-A18 requires 24V / 230 mA to power the RF switch, supplied from the power adaptor (included).
GUI Software CD, programming instructions, USB & Ethernet cables, and 24VDC power adaptor included	The RC-2SP4T-A18 comes ready to use out of the box with all software, accessories, and instructions needed for immediate operation included.
Switch Cycle Counters with automatic Calibration interval alerts	Allows user to monitor the exact usage of each switch and plan calibrations based on actual usage, improving reliability and saving maintenance costs.



Xtra Long Life 100 million cycles

USB/Ethernet RF Switch Matrix RC-2SP4T-A18

50Ω DC to 18 GHz

Features

- Capable of 100 million cycles
- Two DC to 18 GHz SP4T absorptive fail-safe RF switch in break-before-make configuration
- Electromechanical switching (Isolation 85 dB typ.)
- High power handling, 2W
- USB or Ethernet-TCP/IP (HTTP and Telnet) control
- Switch Cycle Counters with automatic calibration interval alerts
- Easy installation and operation
- Supports a wide range of programming environments (See [AN-49-001](#) for details)¹
- Mounting bracket (Optional)
- Protected by US Patents 5,272,458; 6,414,577; 6,650,210; 7,633,361 and 7,843,289

Applications

- R&D
- Automated Test equipment
- Controlling RF signal paths



Case Style: MR1937



Installation CD

Model No.	Description	Qty.
RC-2SP4T-A18	USB/Ethernet RF Switch	(1-9)
Included Accessories		
AC/DC-24-3W1	AC/DC 24V Adapter (see Ordering Information)	1
CBL-3W1-XX	AC Power Cord (see Ordering Information)	1
USB-CBL-AB-3+	2.7 ft USB cable	1
CBL-RJ45-MM-5+	5 ft. Ethernet cable	1
RFSW-CD	Installation CD	1

RoHS Compliant

See our web site for RoHS Compliance methodologies and qualifications

Mini-Circuits RF Switch Control Program for **USB/Ethernet** RF Switch Matrix

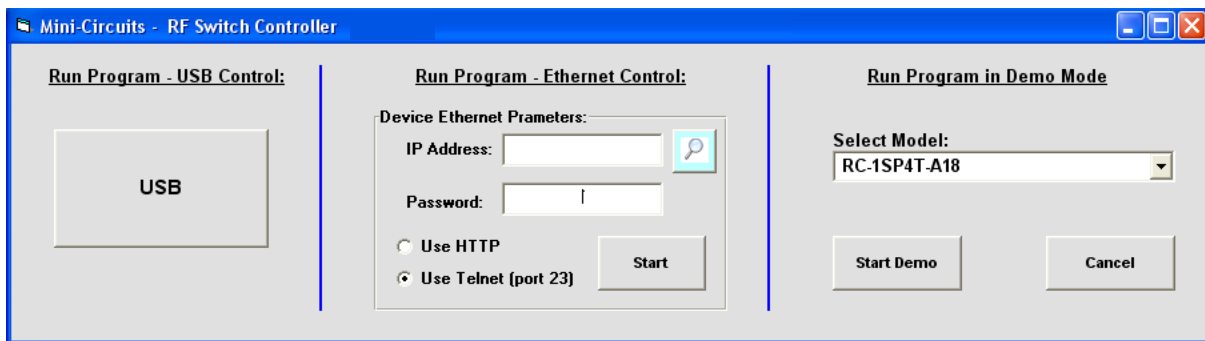

Steps to start RC-2SP4T-A18 GUI via USB

- Click on USB button.
- If more than one unit is connected select S/N from list and click OK.
- Start working.

Steps to start RC-2SP4T-A18 GUI via Ethernet

- Click on search icon.
- Select unit from list of IP addresses and click select
- The selected IP will appear in the IP Address field.
- Select communication protocol (Telnet or HTTP)
- Click on Start and begin working.

- For Demo mode of any Switch Matrix model select the model name from the drop box and click 'Start Demo' (See [user guide](#) for details)
- For programming instructions of the switch matrix see [programming guide](#) and [AN-49-001](#) on Mini-Circuits' website

¹ Windows is a registered trademarks of Microsoft Corporation in the United States and other countries. Linux is a registered trademark of Linus Torvalds. Mac is a registered trademark of Apple Corporation in the United States and other countries.

Neither Mini-Circuits nor the Mini-Circuits RC-2SP4T-A18 are affiliated with or endorsed by the owners of the above referenced trademarks.

Mini-Circuits and the Mini-Circuits logo are registered trademarks of Scientific Components Corporation.

Electrical Specifications

Parameter	Port	Conditions	Min.	Typ.	Max.	Units
Rated Voltage	24V _{DC} IN	provided via external power adapter	23	24	25	V
	USB Port	-	-	5	-	
Power On Sequence: Connect the 24V power, followed by the USB control and/or Ethernet cable before turning on the Switch Matrix.						
Rated Current	24V _{DC} IN	COM -> 1,2,3, or 4 state	-	160	230	mA
		RF Switch @ Disconnect state	-	60	90	
	USB Port	COM -> 1,2,3, or 4 state	-	10	20	
		RF Switch @ Disconnect state	-	10	20	
Switching Time		-	-	25	-	ms
Life (per switch) ²		@ 100 mW (hot switching) ³	10	-	-	million switching cycles
		@ 1 W (hot switching) ³	-	3	-	
RF Power (hot switching) ⁴			-	-	2	
RF VSWR ⁵		DC to 1 GHz	-	1.05	1.10	:1
		1 GHz to 8 GHz	-	1.20	1.40	
		8 GHz to 12 GHz	-	1.20	1.40	
		12 GHz to 18 GHz	-	1.30	1.60	
RF Insertion Loss (per switch)		DC to 1 GHz	-	0.10	0.20	dB
		1 GHz to 8 GHz	-	0.15	0.30	
		8 GHz to 12 GHz	-	0.25	0.40	
		12 GHz to 18 GHz	-	0.50	0.80	
RF Isolation (per switch)		DC to 1 GHz	85	105	-	dB
		1 GHz to 8 GHz	80	100	-	
		8 GHz to 12 GHz	75	95	-	
		12 GHz to 18 GHz	60	80	-	

² Capable of up to 100 million cycles with proper maintenance, contact Mini-Circuits

³ Exceeding these limits will result in reduced life.

⁴ Power handling is specified with RF applied to the COM port and output load connected to 1,2,3, or 4 ports.

⁵ For COM port only when connected to port 1,2,3, or 4. For ports 1,2,3 and 4 only when connected to COM port.

Minimum System Requirements

Interface	USB HID or HTTP Get/Post or Telnet protocols
Host operating system - USB Control	Windows 32/64 Bit operating system: Windows 98®, Windows XP®, Windows Vista®, Windows 7®, Windows 8.® Linux® support: 32/64 Bit operating system
Host operating system - Ethernet Control	Any Windows®, Mac®, or Linux® computer with a network port and Ethernet-TCP/IP (HTTP or Telnet protocols) support
Hardware	Pentium® II or better ⁵

⁵ Pentium® is a registered trademark of Intel Corporation

Connections

24V _{DC} IN	(2.1 mm center positive DC Socket)
RF Switch A (1, 2, 3 4, COM)	(SMA female)
RF Switch B (1, 2, 3 4, COM)	(SMA female)
USB	(USB type B receptacle)
Network (Ethernet/LAN)	(RJ45 socket)

Absolute Maximum Ratings

Operating Temperature	0°C to 40°C
Storage Temperature	-15°C to 45°C
DC Voltage max.	26V
RF power	2W

Permanent damage may occur if any of these limits are exceeded.

Block Diagram

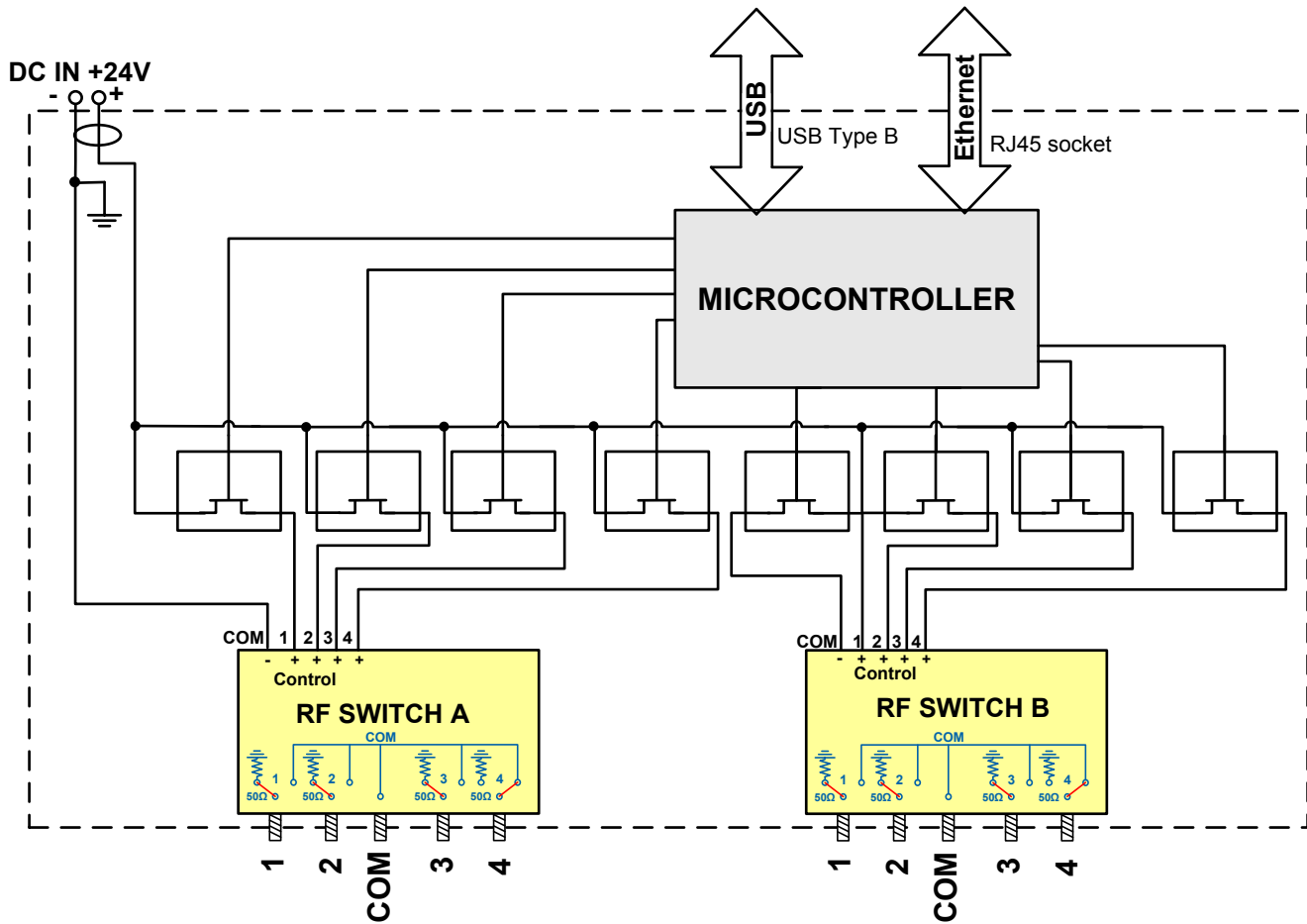

Outline Drawing (MR1937)

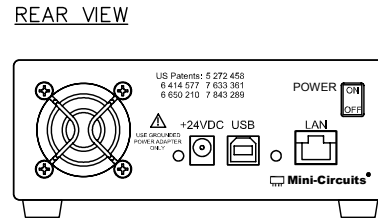
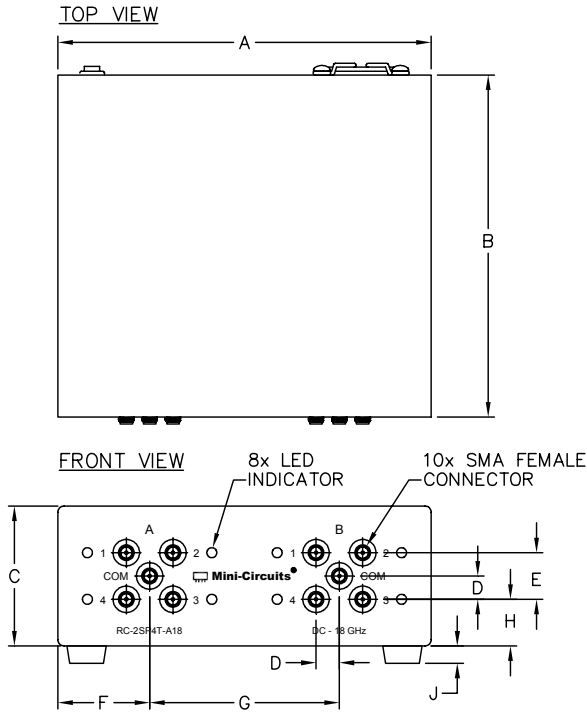

BRACKET OPTION ONE SET OF 2 EACH.

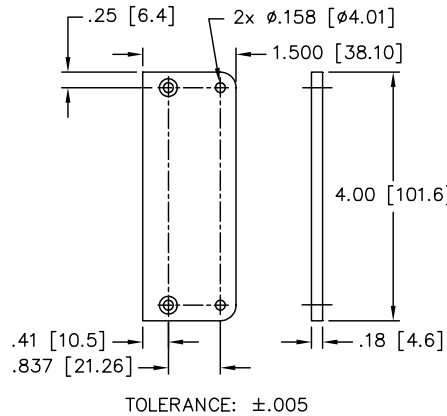

INSTRUCTION FOR MOUNTING BRACKETS:
TOOL REQUIRED:
PHILLIPS HEAD SCREW DRIVER

STEP 1: REMOVE RUBBER FEET FROM THE BOTTOM OF THE UNIT. DO NOT DISCARD THE FASTENERS.

STEP 2: MOUNT THE BRACKETS WITH THE FASTENERS REMOVED IN STEP 1, USING THE COUNTER-BORE HOLES IN THE BRACKET.

Outline Dimensions ($\frac{\text{inch}}{\text{mm}}$)

A	B	C	D	E	F	G	H	J	K	L	M	wt
6.00	5.50	2.25	0.38	0.75	1.47	3.05	0.75	0.28	3.500	0.375	6.75	grams
152.4	139.7	57.2	9.65	19.05	37.34	77.47	19.05	7.1	88.9	9.53	171.5	1180

Configuration A: Two SP4T switches

- Power handling is specified with RF applied to the COM port and output load connected to either 1,2,3, or 4 of the respective switch.
- When connecting a coaxial semi flex cable, tighten connectors alternately using an 8in/lb torque wrench to insure proper contact at each end.

Power Supply Indicator:
● ON
● - Disconnected
● - Connected

USB Control

Ethernet-Config

Main Control

SW A
 1 2 3 4
 16 15
 14 13

SW B
 1 2 3 4
 12 11
 12 15

SW A:
 COM -> 1
 COM -> 2
 COM -> 3
 COM -> 4
 Disconnect

SW B:
 COM -> 1
 COM -> 2
 COM -> 3
 COM -> 4
 Disconnect

User Sequence

Model Name: RC-2SP4T-A18
Serial Number: (fw) 11403110008
Address (1 to 255): 255 Set

Standard Switch Configurations:
 Dual SP4T

Note: Switches A, B move independently.

Config. A

IN (COM_A)

Out 1 (1A) Out 2 (2A) Out 3 (3A) Out 4 (4A)

IN (COM_B)

Out 1 (1B) Out 2 (2B) Out 3 (3B) Out 4 (4B)

SP4T: Switch A or B Logic:
 Disconnected : 0000
 IN ↔ Out1 : 0001
 IN ↔ Out2 : 0010
 IN ↔ Out3 : 0100
 IN ↔ Out4 : 1000

Switches move independently.

Configuration B: Dual SP4T switches

- Power handling is specified with RF applied to the COM port and output load connected to either 1,2,3, or 4 of the respective switch.
- When connecting a coaxial semi flex cable, tighten connectors alternately using an 8in/lb torque wrench to insure proper contact at each end.

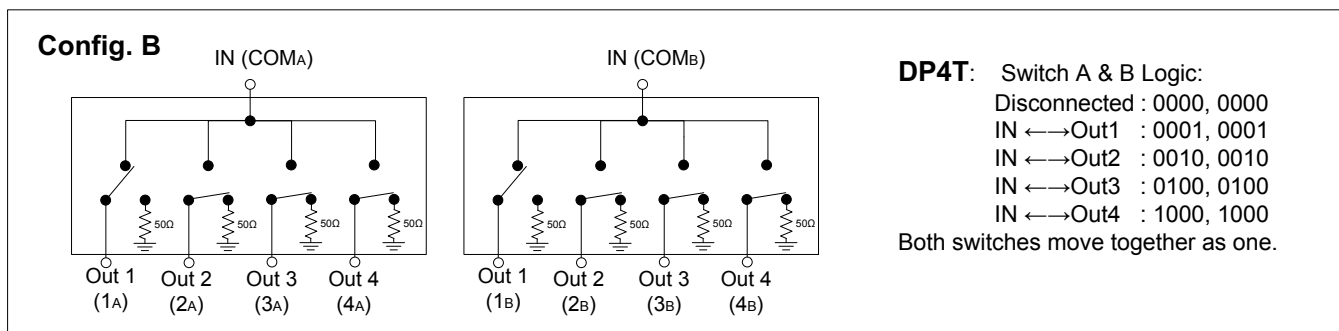
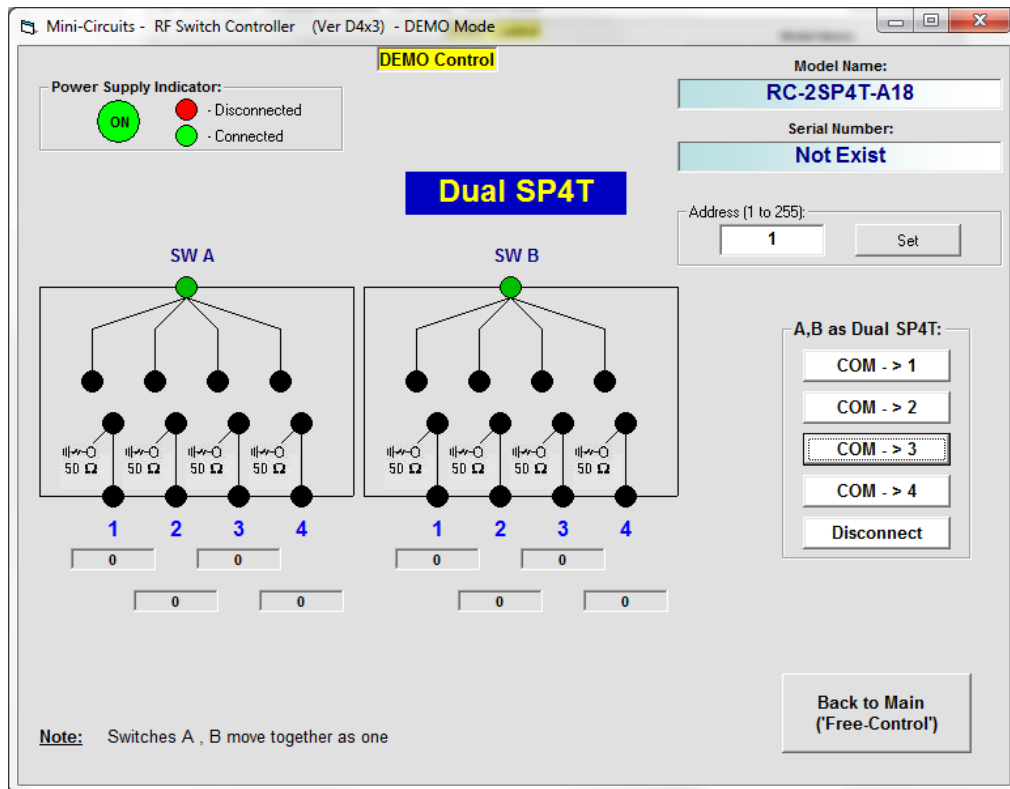

User Switching Sequence - for setting any configuration or sequence needed

- Power handling is specified with RF applied to the COM port and output load connected to either 1 or 2 of the respective switch.
- When connecting a coaxial semi flex cable, tighten connectors alternately using an 8in/lb torque wrench to insure proper contact at each end.

Mini-Circuits - RF Switch Controller (Ver D4x3) - DEMO Mode

POWER SUPPLY INDICATOR: **ON** (Green) - Connected, (Red) - Disconnected

USER SWITCHING SEQUENCE
 Model Name: **RC-2SP4T-A18** Serial Number: **Not Exist**

Step	SW A	SW B	dwell (mSec)	Exec Program
Step 1	COM->1	COM->3	70	
Step 2	COM->2	COM->4	25	
Step 3	DISCONNECT	DISCONNECT	500	monitor.exe
Step 4	COM->3	COM->1	30	
Step 5	COM->1	COM->3	50	
Step 6	COM->4	COM->2	42	

Run Sequence: Count Limit: [] Counter: 6 Time Limits(min): [] Elapsed (min): 0.10

View Switches

Buttons: Add, Insert, Remove, Current Step, Continuously, Stop, Back to Main ('Free-Control')



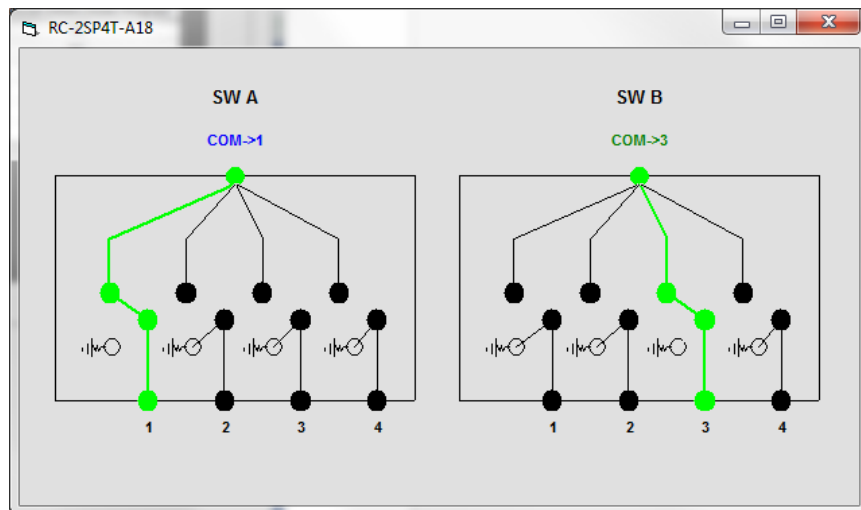

Check this box to show graphical presentation of current switch state (shown below)







- For instructions on using the GUI See the [user guide](#) on Mini-Circuits' website
- For programming instructions of the switch matrix see the [programming guide](#) and [AN-49-001](#) on Mini-Circuits' website

Ordering, Pricing & Availability Information see our web site

Model	Description
RC-2SP4T-A18	USB/Ethernet RF SP4T Switch Matrix

Included Accessories	Part No.	Description
	AC/DC-24-3W1	AC/DC 24V _{DC} Grounded Power Adaptor. Operating temperature: 0°C to +40°C, I _{Max} =2.5A
	CBL-3W1-XX	AC Power Cord (Select one power cord from below with each Switch Matrix box)
	RFSW-CD	Software CD
	USB-CBL-AB-3+	2.7 ft (0.8 m) USB Cable: USB type A(Male) to USB type B(Male)
	CBL-RJ45-MM-5+	5 ft (1.5 m) Ethernet cable: RJ45(Male) to RJ45(Male) Cat 5E cable

AC Power Cords ⁶	Part No.	Description
	CBL-3W1-US	Power Cord for United States
	CBL-3W1-EU	Power Cord for Europe
	CBL-3W1-UK	Power Cord for United Kingdom
	CBL-3W1-AU	Power Cord for Australia and China
	CBL-3W1-IL	Power Cord for Israel

⁶ Power cords for other countries are also available, if you need a power cord for a country not listed in the table please contact apps@minicircuits.com or check <http://www.minicircuits.com/contact/offices.html> for regional offices e-mail and phone numbers.

Optional Accessories	Description
USB-CBL-3+ (spare)	2.7 ft (0.8 m) USB Cable: USB type A(Male) to USB type B(Male)
USB-CBL-7+	6.8 ft (2.1 m) USB Cable: USB type A(Male) to USB type B(Male)
USB-CBL-11+	11 ft (3.4 m) USB Cable: USB type A(Male) to USB type B(Male)
CBL-RJ45-MM-5+ (spare)	5 ft (1.5 m) Ethernet cable: RJ45(Male) to RJ45(Male) Cat 5E cable
BKT-272-08+	Bracket (One set of 2 each)

Additional Notes

- A. Performance and quality attributes and conditions not expressly stated in this specification document are intended to be excluded and do not form a part of this specification document.
- B. Electrical specifications and performance data contained in this specification document are based on Mini-Circuit's applicable established test performance criteria and measurement instructions.
- C. The parts covered by this specification document are subject to Mini-Circuits standard limited warranty and terms and conditions (collectively, "Standard Terms"); Purchasers of this part are entitled to the rights and benefits contained therein. For a full statement of the Standard Terms and the exclusive rights and remedies thereunder, please visit Mini-Circuits' website at www.minicircuits.com/MCLStore/terms.jsp