

## Silicon Double Balanced HMIC Mixer 1700 - 2300 MHz

Rev. V3

### Features

- Low Cost Miniature Plastic Package
- 6.6 dB Typical Conversion Loss at 1900 MHz
- 6.7 dB Typical Conversion Loss at 2200 MHz
- +13 to +17 dBm LO Drive
- HMIC™ Process
- Silicon High Barrier Schottky Diodes
- DC - 500 MHz IF Bandwidth
- RoHS\* Compliant with 260 °C. Reflow Capability
- 100% MATTE Tin Plating

### Description and Applications

MA4EX190H1-1225T is a silicon monolithic 1700-2300 MHz double balanced mixer in a low cost miniature surface mount SOT-25 package. The die uses M/A-COM's unique HMIC™ silicon/glass process to achieve low loss passive elements while retaining the advantages of low barrier silicon Schottky diodes.

These mixers are well suited for high volume wireless and cellular applications where small size and repeatability are required. Typical applications include frequency conversion, modulation, and demodulation for receivers and transmitters in both portable cellular and base station applications.

### Ordering Information

Standard Part Number	Package
MA4EX190H1-1225T	Tape and Reel

### Absolute Maximum Ratings<sup>1</sup>

Parameter	Maximum Ratings
Operating Temperature	-40°C to +85°C
Storage Temperature	-65°C to 150°C
Incident LO Power	+20 dBm
Incident RF Power	+20 dBm
Solder Temperature	+260°C

1. Exceeding these limits may cause permanent damage.

\*Restrictions on Hazardous Substances, European Union Directive 2002/95/EC.

### SOT-25 Package Outline (Topview)

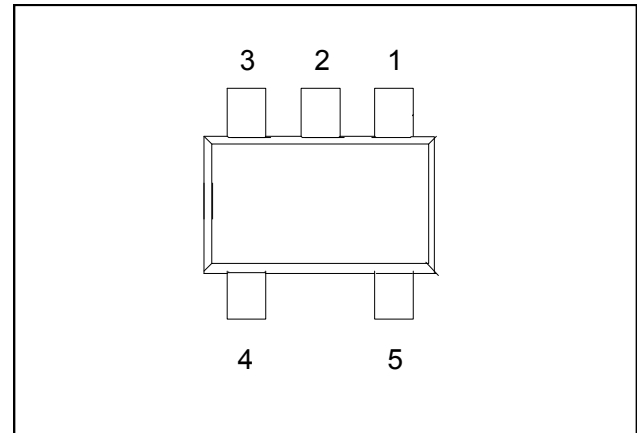

### PIN Configuration

PIN	Function	PIN	Function
1	RF	4	GND
2	GND	5	IF
3	LO		

### Schematic

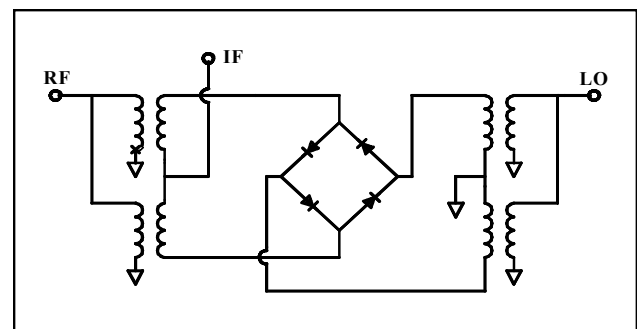

## Silicon Double Balanced HMIC Mixer 1700 - 2300 MHz

Rev. V3

### Electrical Specifications @ +25 °C

Parameter	Frequency Range	Test Conditions	Units	Min.	Typ.	Max.
Conversion Loss	1900 MHz 1700-2300 MHz	LO Drive = +15 dBm RF = -10 dBm, IF = 60 MHz	dB dB		6.6 6.7	7.0 8.0
L - R Isolation	1900 MHz 1700-2300 MHz	LO Drive = +15 dBm RF Level = -10 dBm	dB dB		30.0 30.0	
L - I Isolation	1900 MHz 1700-2300 MHz	LO Drive = +15 dBm RF Level = -10 dBm	dB dB		28.0 28.0	
R - I Isolation	1900 MHz 1700-2300 MHz	LO Drive = +15 dBm RF Level = -10 dBm	dB dB		23.0 20.0	
RF VSWR	1900 MHz 1700-2300 MHz	LO Drive = +15 dBm RF Level = -10 dBm			1.10:1 1.20:1	
IF VSWR	DC - 500 MHz	LO Drive = +15 dBm RF Level = -10 dBm			1.40:1	-
Input IP3	1900 MHz 1850-2300 MHz	LO Drive = +15 dBm IF = 60 MHz	dBm dBm	23 23	26.0 26.0	
Input 1 dB Compression	1900 MHz 1700-2300 MHz	LO Drive = +17 dBm IF = 60 MHz	dBm dBm		10.5 10.5	- -
IF 1 dB Bandwidth			MHz	0	500	-

### Typical Performance Curves (LO Drive = +15 dBm, RF = -10 dBm, IF = 60 MHz)

**Conversion Loss**

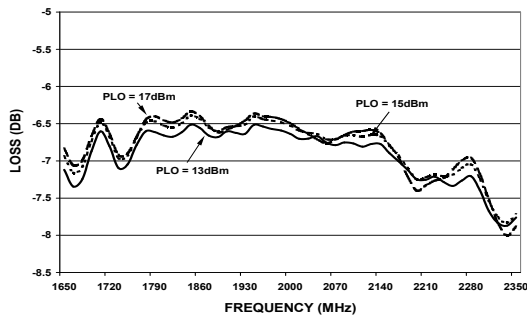

**Isolation**

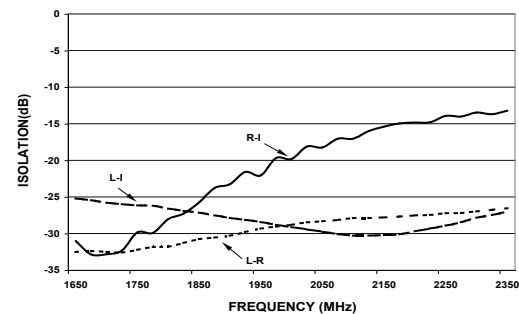

**VSWR**

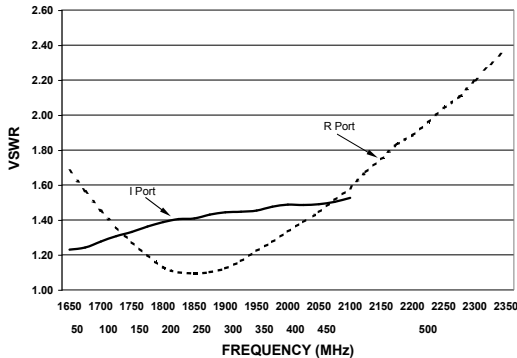

**Input IP3 & 1dB Compression Point**

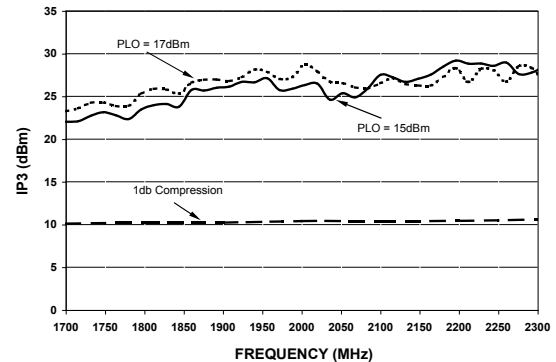

# MA4EX190H1-1225T



**Silicon Double Balanced HMIC Mixer**  
**1700 - 2300 MHz**

Rev. V3

## Case Style - SOT-25

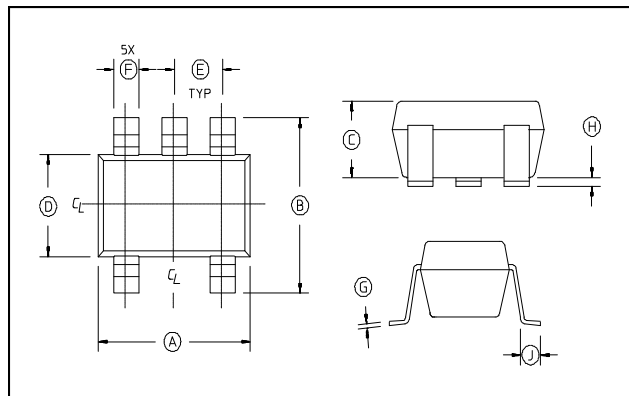

## SOT-25 Dimensions

Dim	Inches		Millimeters	
	Min.	Max.	Min.	Max.
A	.106	.122	2.70	3.10
B	.100	.118	2.54	3.00
C	—	.051	—	1.30
D	.063 REF.		1.60 REF.	
E	.032	.043	.80	1.10
F	.014	.020	.35	.50
G	.003	—	.08	—
H	.000	.006	.00	.15
J	.018 REF.		.45 REF.	

2. Leads Coplanarity should be 0.003 (0.08) max.

M/A-COM Technology Solutions Inc. All rights reserved.

Information in this document is provided in connection with M/A-COM Technology Solutions Inc ("MACOM") products. These materials are provided by MACOM as a service to its customers and may be used for informational purposes only. Except as provided in MACOM's Terms and Conditions of Sale for such products or in any separate agreement related to this document, MACOM assumes no liability whatsoever. MACOM assumes no responsibility for errors or omissions in these materials. MACOM may make changes to specifications and product descriptions at any time, without notice. MACOM makes no commitment to update the information and shall have no responsibility whatsoever for conflicts or incompatibilities arising from future changes to its specifications and product descriptions. No license, express or implied, by estoppel or otherwise, to any intellectual property rights is granted by this document.

THESE MATERIALS ARE PROVIDED "AS IS" WITHOUT WARRANTY OF ANY KIND, EITHER EXPRESS OR IMPLIED, RELATING TO SALE AND/OR USE OF MACOM PRODUCTS INCLUDING LIABILITY OR WARRANTIES RELATING TO FITNESS FOR A PARTICULAR PURPOSE, CONSEQUENTIAL OR INCIDENTAL DAMAGES, MERCHANTABILITY, OR INFRINGEMENT OF ANY PATENT, COPYRIGHT OR OTHER INTELLECTUAL PROPERTY RIGHT. MACOM FURTHER DOES NOT WARRANT THE ACCURACY OR COMPLETENESS OF THE INFORMATION, TEXT, GRAPHICS OR OTHER ITEMS CONTAINED WITHIN THESE MATERIALS. MACOM SHALL NOT BE LIABLE FOR ANY SPECIAL, INDIRECT, INCIDENTAL, OR CONSEQUENTIAL DAMAGES, INCLUDING WITHOUT LIMITATION, LOST REVENUES OR LOST PROFITS, WHICH MAY RESULT FROM THE USE OF THESE MATERIALS.

MACOM products are not intended for use in medical, lifesaving or life sustaining applications. MACOM customers using or selling MACOM products for use in such applications do so at their own risk and agree to fully indemnify MACOM for any damages resulting from such improper use or sale.