

# BT013

## 1500-4000 MHz Medium Power Amplifier



### Device Features

- OIP3 = 45.0 dBm @ 1900 MHz
- Gain = 15.0 dB @ 1900 MHz
- Output P1 dB = 27.5 dBm @ 1900 MHz
- 50 Ω Cascadable
- Patented Over Voltage Protection Circuit
- Lead-free/RoHS-compliant SOT-89 SMT package



### Product Description

BeRex's BT013 is a high performance and a high dynamic range amplifier in a low cost surface mount package(SOT-89) with a RoHS-compliant, that incorporates reliable heterojunction-bipolar-transistor (HBT) devices fabricated with InGaP GaAs technology. This device is designed for use where high linearity is required and features high OIP3 and P1 with low consumption current (135mA) and requires a few external matching components such as a DC blocking capacitors on the In/Output pin, a bypass capacitor and a RF choke for the out port. All devices are 100% RF/DC tested.

### Applications

- Base station Infrastructure/RFID
- Commercial/Industrial/Military wireless system

### Application Circuits

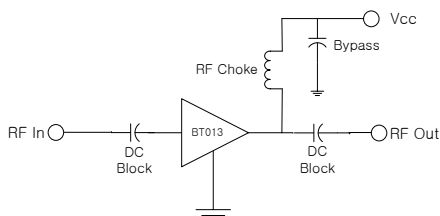

\*external matching circuit: refer to the page 6 to 12.

### Typical Performance<sup>1</sup>

Parameter	Frequency				Unit
	1900	2140	2400	3500	
Gain	15.0	14.0	13.2	10.7	dB
S11	-17.5	-12.0	-13.0	-26.0	dB
S22	-12.5	-12.0	-13.0	-25.0	dB
OIP3 <sup>2</sup>	45.0	45.0	43.0	40.0	dBm
P1dB	27.5	27.2	27.0	26.0	dBm
IS-95C ACPR	21.0	-	-	-	dBm
WCDMA ACLR	-	19.5	18.5	-	dBm
Noise Figure	6.8	6.8	6.8	7.1	dB

<sup>1</sup> Device performance \_ measured on a BeRex evaluation board at 25°C, 50 Ω system.

<sup>2</sup> OIP3 \_ measured with two tones at an output of 13 dBm per tone separated by 1 MHz.

\*ACPR&ACLR CH Power \_ measured at 45dBc.

	Min.	Typical	Max.	Unit
Bandwidth	1500		4000	MHz
I <sub>c</sub> @ (V <sub>c</sub> = 5V)	115	135	155	mA
V <sub>c</sub>		5.0		V
R <sub>TH</sub>		50		°C/W

### Absolute Maximum Ratings

Parameter	Rating	Unit
Operating Case Temperature	-40 to +85	°C
Storage Temperature	-55 to +155	°C
Junction Temperature	+220	°C
Operating Voltage	+7.0	V
Supply Current	200	mA
Input RF Power	23	dBm

\*Operation of this device above any of these parameters may result in permanent damage.

# BT013

## 1500-4000 MHz Medium Power Amplifier



### V-I Characteristics

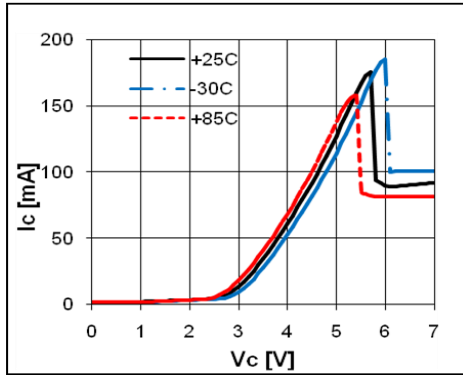

\*Voltage protection works at 5~6 V

### BeRex SOT89 Evaluation Board

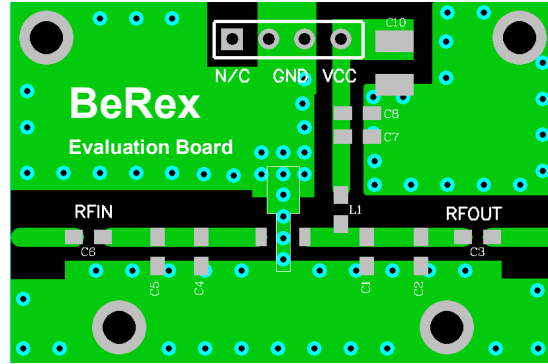

\*Dielectric constant \_ 4.2 \*RF pattern width 52mil \*31mil thick FR4 PCB

## Typical Device Data

S-parameters (Vc=5V, Ic=135mA, T=25°C)

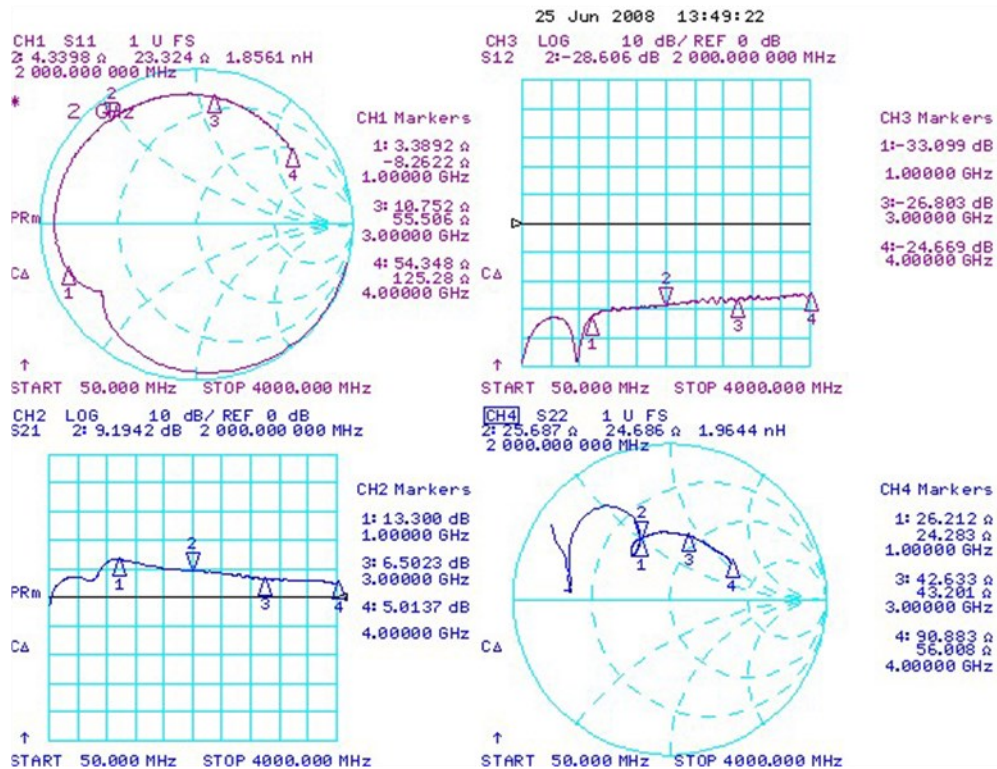

# BT013

## 1500-4000 MHz Medium Power Amplifier



### S-Parameter

(V<sub>device</sub> = 5.0V, I<sub>cc</sub> = 135mA, T = 25 °C, calibrated to device leads)

Freq [MHz]	S11 [Mag]	S11 [Ang]	S21 [Mag]	S21 [Ang]	S12 [Mag]	S12 [Ang]	S22 [Mag]	S22 [Ang]
100	-0.046	-30.149	2.219	-128.4	-41.958	66.107	-3.497	165.97
500	-0.952	-116.77	6.737	-174.18	-32.703	25.318	-3.457	162.64
1000	-1.111	-162.01	13.26	161.56	-32.513	76.255	-7.557	117.5
1500	-0.928	157.99	10.718	121.35	-30.171	46.516	-7.780	127.17
2000	-1.240	129.31	9.181	101.55	-28.599	42.527	-7.262	116.25
2500	-1.390	104.6	8.334	81.201	-26.76	37.808	-7.180	97.537
3000	-1.669	82.694	6.491	66.725	-26.706	32.623	-7.38	74.648
3500	-1.989	60.455	6.124	51.795	-25.792	26.141	-7.336	50.666
4000	-2.281	37.752	5.024	33.795	-24.653	20.698	-6.823	32.131

# BT013

## 1500-4000 MHz Medium Power Amplifier



### WCDMA 6FA 2140 -55dBc

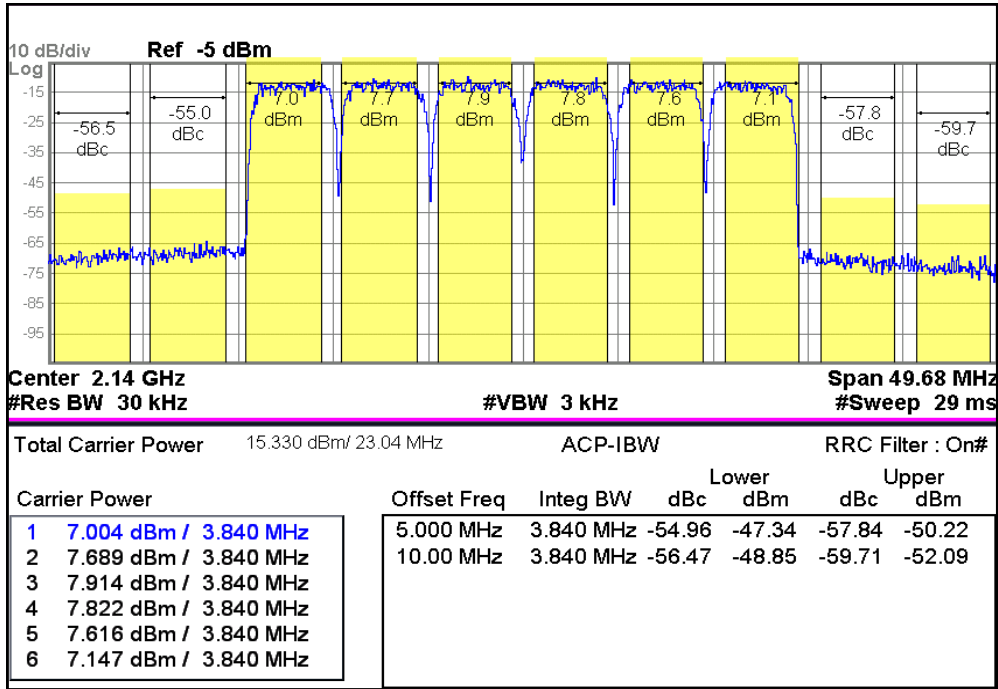

### WCDMA 6FA 2140 -60dBc

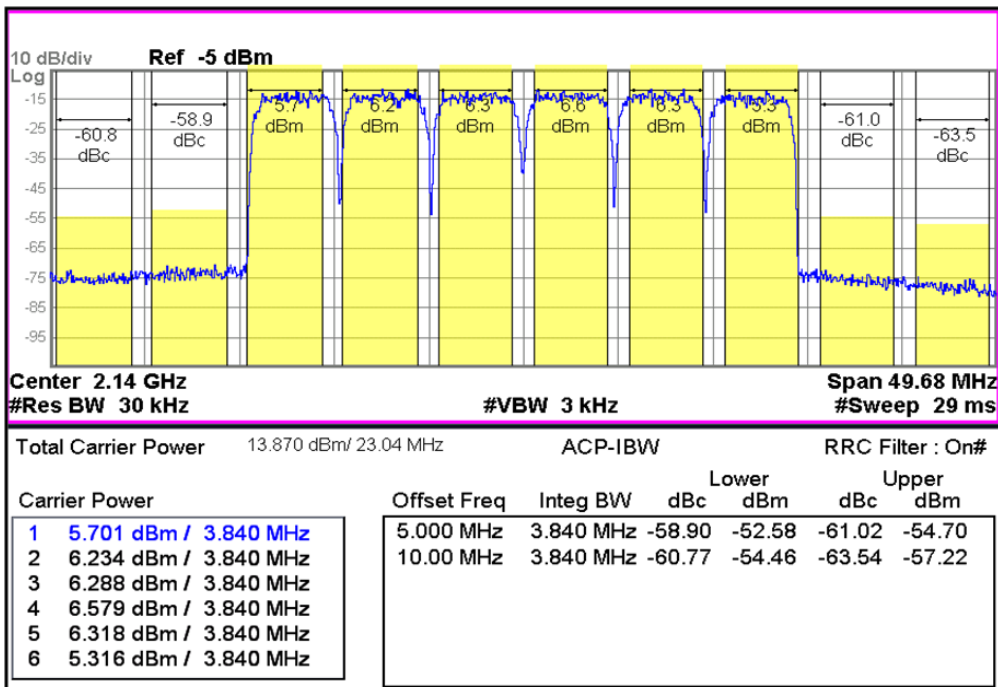

# BT013

1500-4000 MHz Medium Power Amplifier



## ACLR

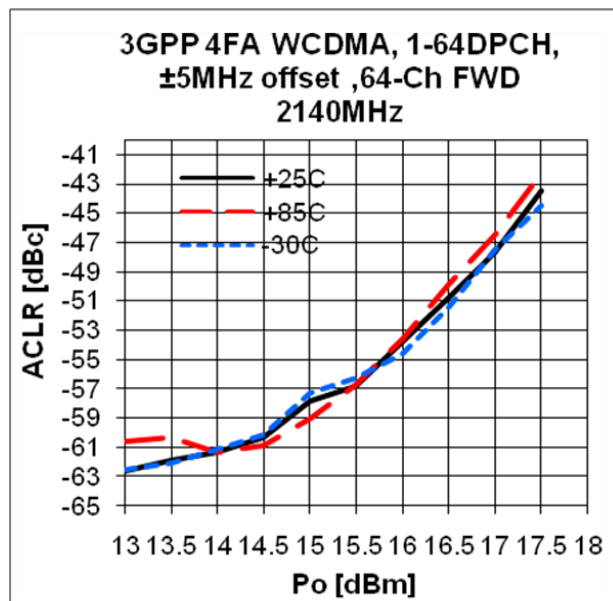

# BT013

1500-4000 MHz Medium Power Amplifier



## Application Circuit: 1900 MHz

Schematic Diagram	BOM		Tolerance
	C1	100pF	±5%
	C2	1000pF	±5%
	C3	10uF	±20%
	C4	22pF	±5%
	C5	22pF	±5%
	C6	3pF	±5%
	C7	0.5pF	±5%
	L1	100nH	±5%

	<p><b>Note:</b></p> <ol style="list-style-type: none"> <li>1. PCB: 31mil thick FR4.</li> <li>2. Distance between the center of the shunt cap (C6) and the input pin of BT013 <u><b>3.2mm.</b></u></li> <li>3. Distance between the center of the shunt cap (C7) and the output pin of BT013 <u><b>8.3mm.</b></u></li> </ol>
--	---

# BT013

## 1500-4000 MHz Medium Power Amplifier



### Typical Performance

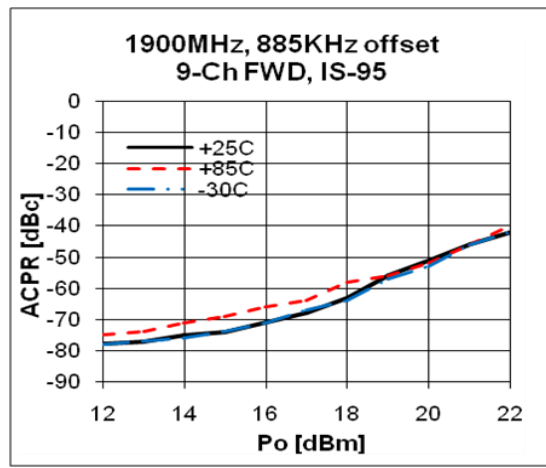
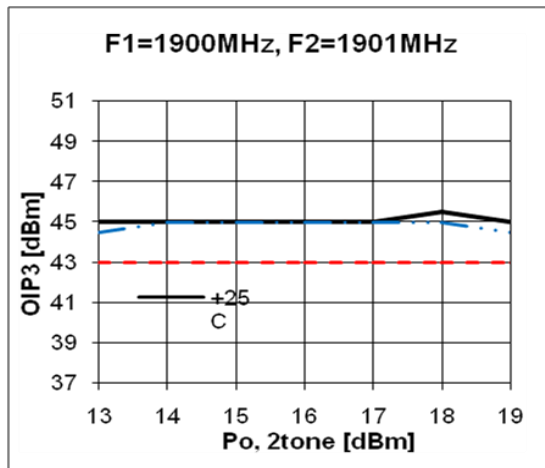
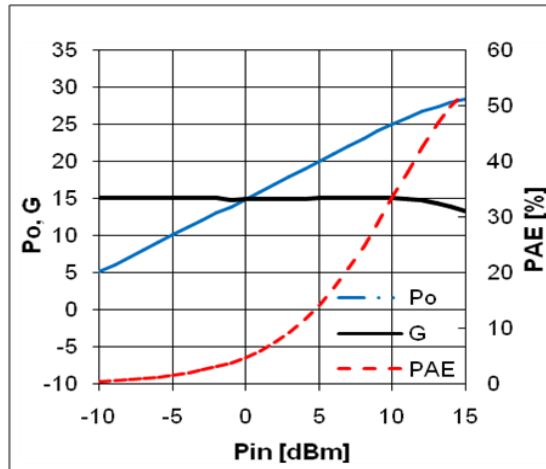
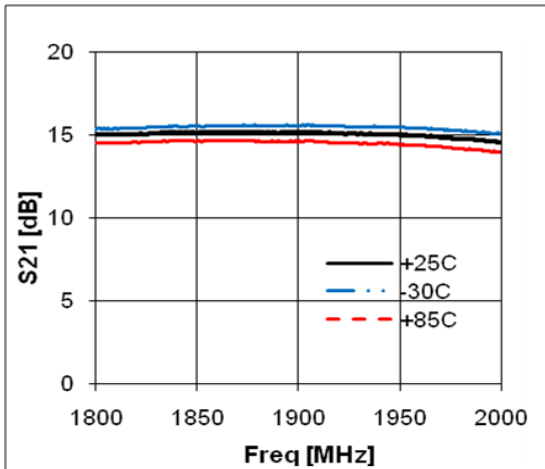
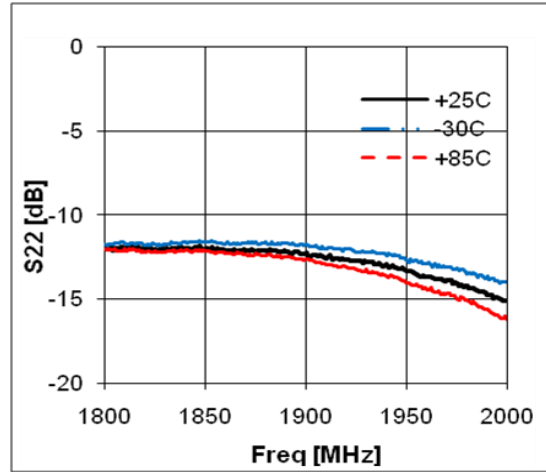
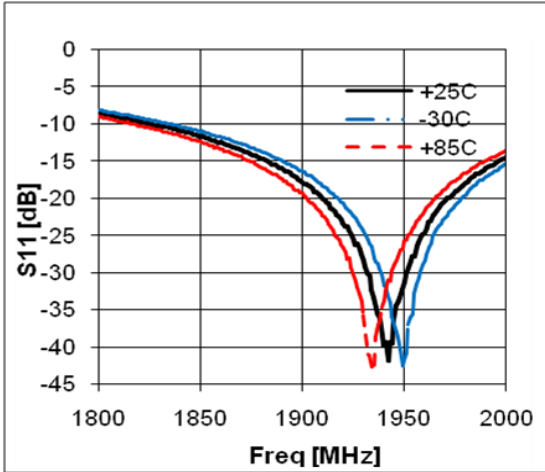

# BT013

1500-4000 MHz Medium Power Amplifier



## Application Circuit: 2140MHz

Schematic Diagram		BOM	Tolerance
	C1	100pF	±5%
	C2	1000pF	±5%
	C3	10uF	±20%
	C4	24pF	±5%
	C5	24pF	±5%
	C6	3pF	±5%
	C7	0.5pF	±5%
	L1	33nH	±5%

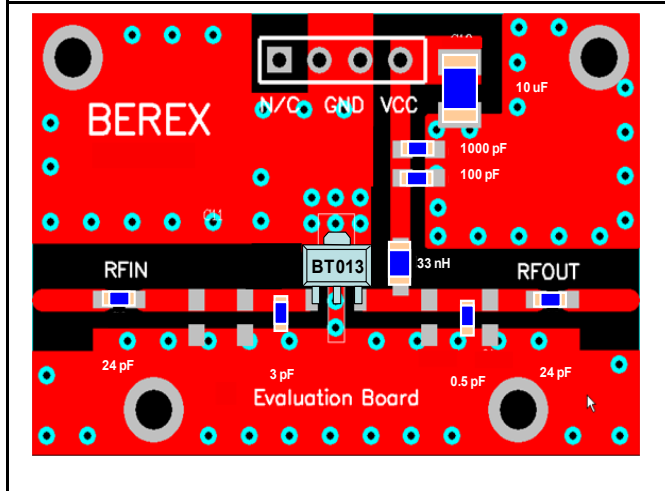

### Note:

1. PCB: 31mil thick FR4
2. Distance between the center of the shunt cap (C6) and the input pin of BT013 **1.5mm.**
3. Distance between the center of the shunt cap (C7) and the output pin of BT013 **6.4mm.**



# BT013

## 1500-4000 MHz Medium Power Amplifier



### Typical Performance

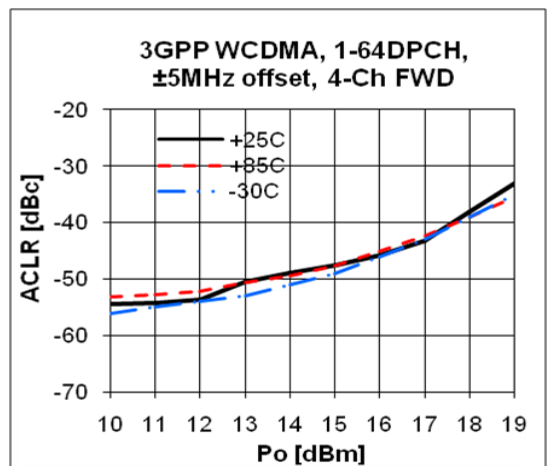
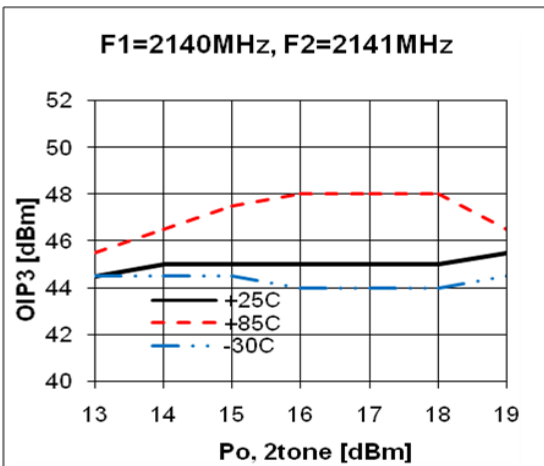
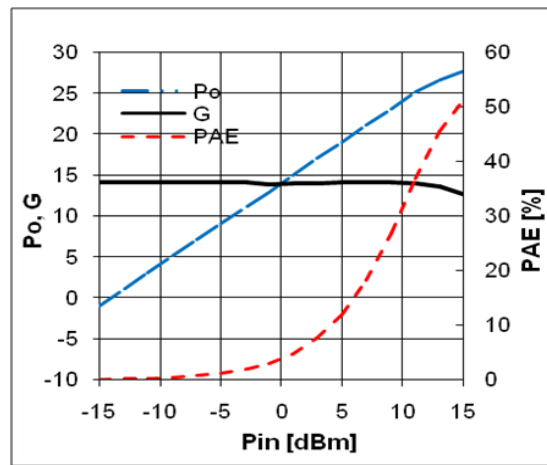
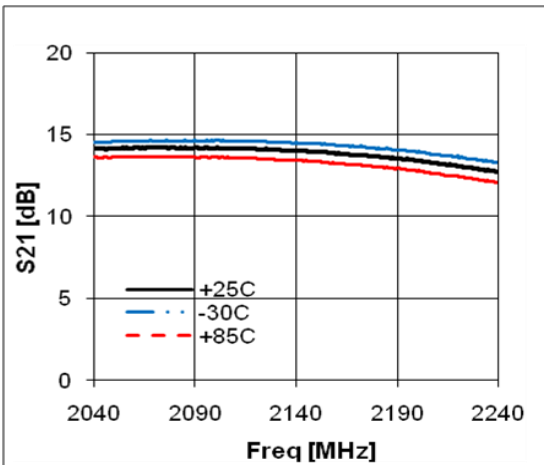
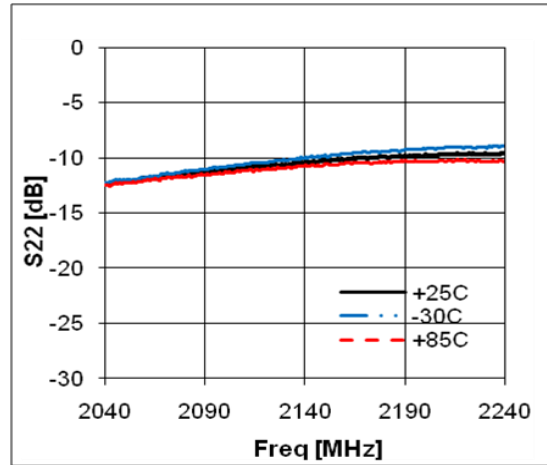
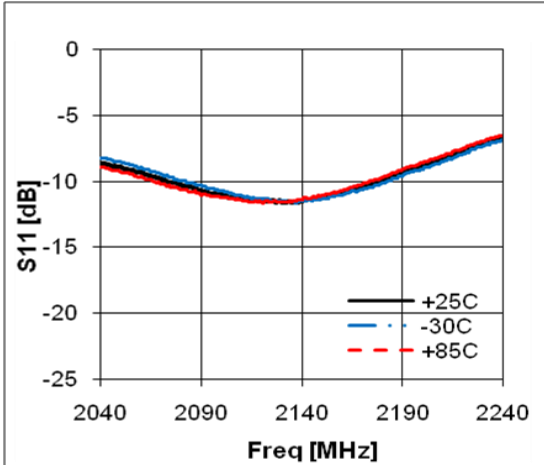

# BT013

1500-4000 MHz Medium Power Amplifier



## Application Circuit: 2400MHz

Schematic Diagram	BOM	Tolerance
	C1	100pF ±5%
	C2	1000pF ±5%
	C3	10uF ±15%
	C4	100pF ±5%
	C5	100pF ±5%
	C6	2pF ±5%
	C7	0.5pF ±5%
L1	33nH ±5%	

	<p>Note:</p> <ol style="list-style-type: none"> <li>1. PCB: 31mil thick FR4</li> <li>2. Distance between the center of the shunt cap (C6) and the input pin of BT013 <u><b>0.7mm.</b></u></li> <li>3. Distance between the center of the shunt cap (C7) and the output pin of BT013 <u><b>3.2mm.</b></u></li> </ol>
--	---

# BT013

## 1500-4000 MHz Medium Power Amplifier



### Typical Performance

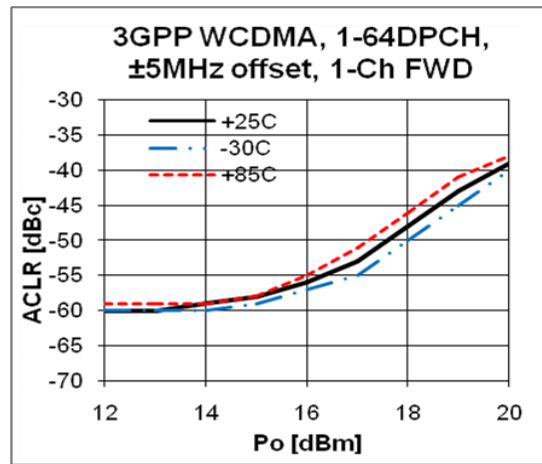
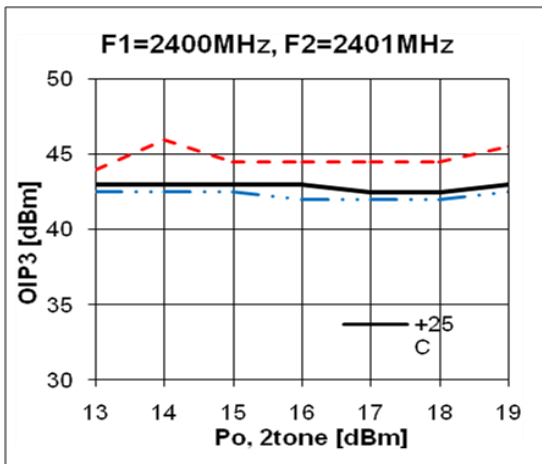
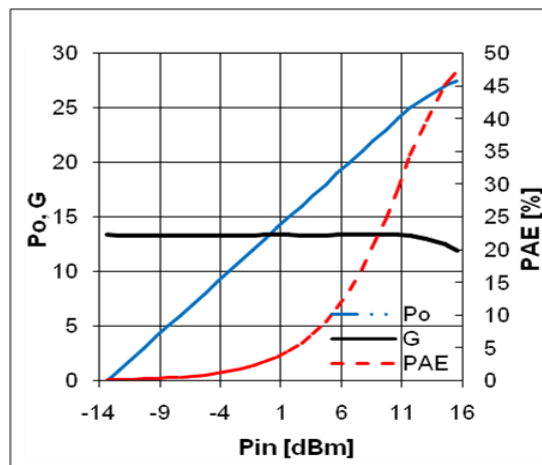
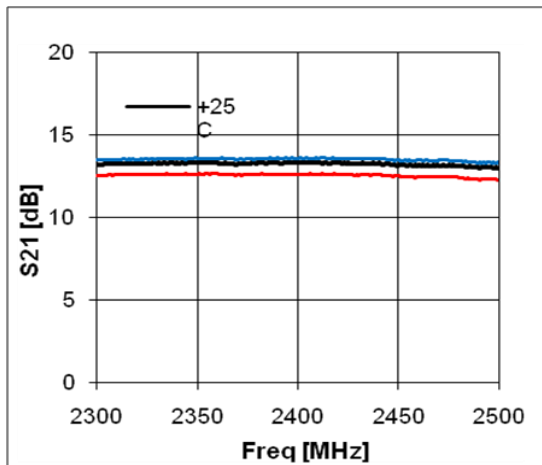
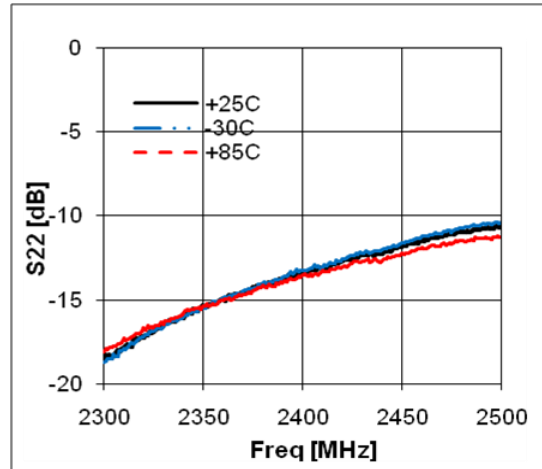
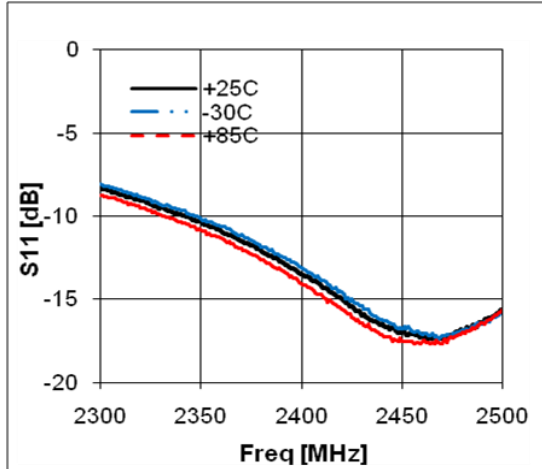

# BT013

## 1500-4000 MHz Medium Power Amplifier



### Application Circuit: 3500MHz

Schematic Diagram		BOM	Tolerance
	C1	100pF	±5%
	C2	1000pF	±5%
	C3	10uF	±20%
	C4	22pF	±5%
	C5	22pF	±5%
	C6	0.75pF	±5%
	C7	0.5pF	±5%
	C8	0.5pF	±5%
L1	33nH	±5%	

**Note:**

1. PCB: 31mil thick FR4
2. Distance between the center of the shunt cap (C6) and the input pin of BT013 \_ **10mm.**
3. Distance between the center of the series cap (C7) and the input pin of BT013 \_ **4mm.**
4. Distance between the center of the shunt cap (C8) and the output pin of BT013 \_ **3mm.**

# BT013

## 1500-4000 MHz Medium Power Amplifier



### Typical Performance

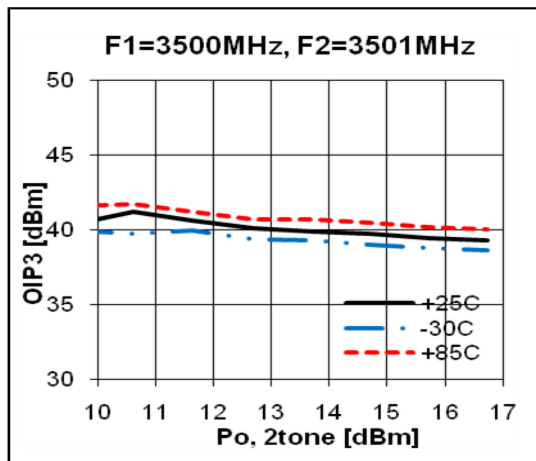
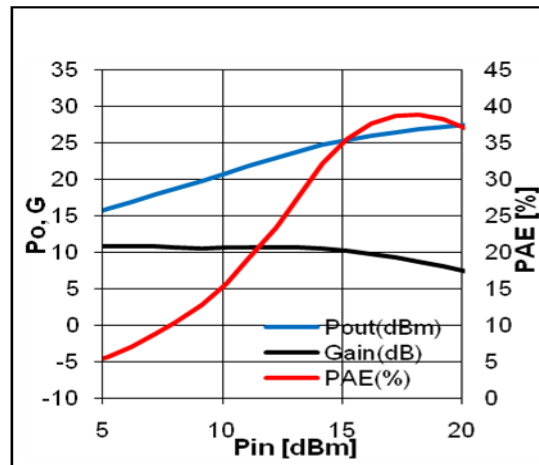
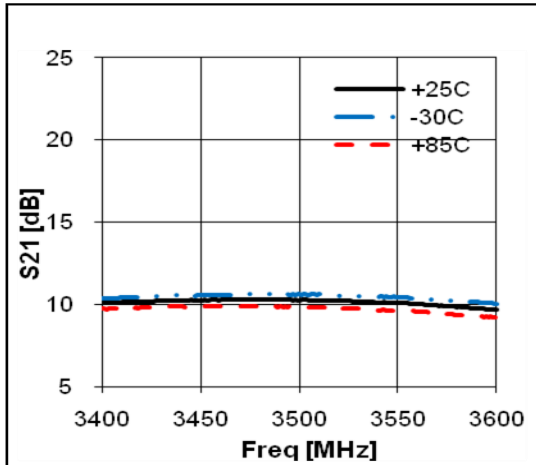
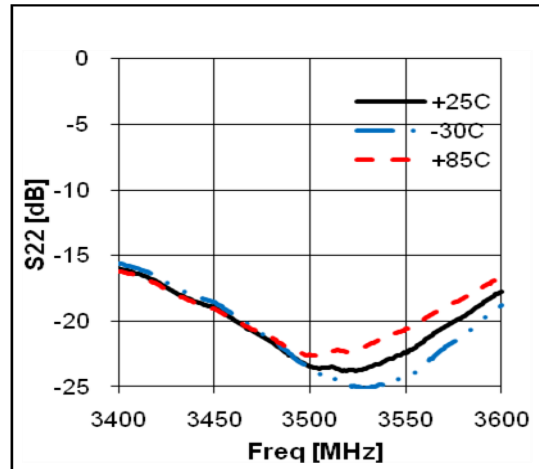
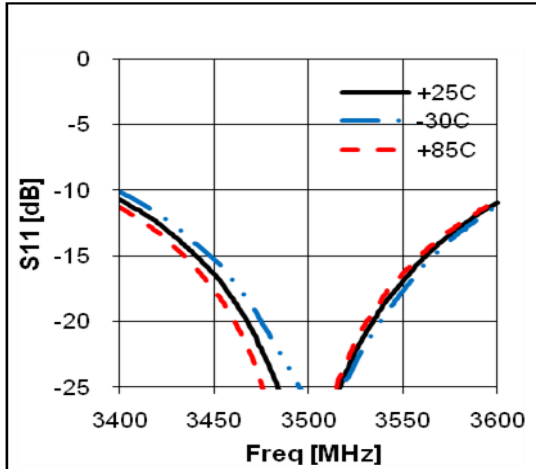

# BT013

## 1500-4000 MHz Medium Power Amplifier



### Package Outline Dimension

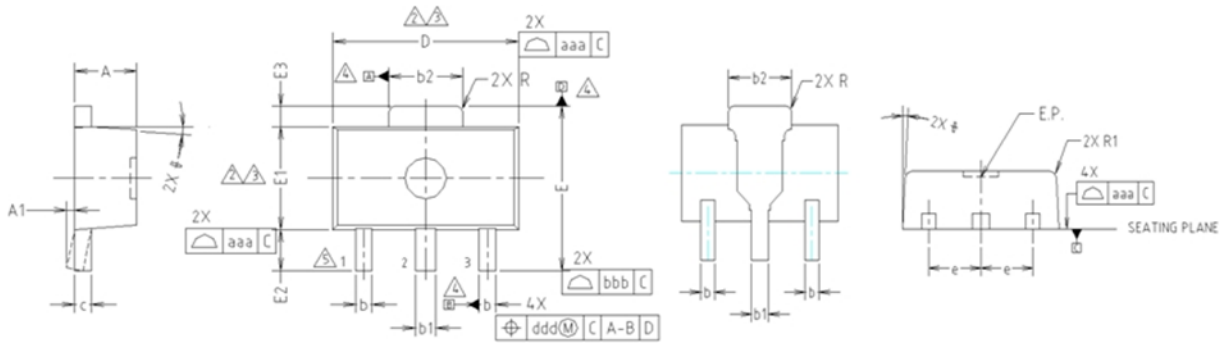

- NOTE:**  
 1. DIMENSIONS IN MILLIMETERS.
- ⚠ DIMENSION D DOES NOT INCLUDE MOLD FLASH, PROTRUSIONS OR GATE BURRS. MOLD FLASH, PROTRUSIONS OR GATE BURRS SHALL NOT EXCEED 0.5mm PER END. DIMENSION E1 DOES NOT INCLUDE INTERLEAD FLASH OR PROTRUSION. INTERLEAD FLASH OR PROTRUSION SHALL NOT EXCEED 0.5mm PER SIDE.
  - ⚠ DIMENSIONS D AND E1 ARE DETERMINED AT THE OUTMOST EXTREMES OF THE PLASTIC BODY EXCLUSIVE OF MOLD FLASH, TIE BAR BURRS, GATE BURRS AND INTERLEAD FLASH, BUT INCLUDING ANY MISMATCH BETWEEN THE TOP AND BOTTOM OF THE PLASTIC BODY.
  - ⚠ DATUMS A, B AND D TO BE DETERMINED 0.18mm FROM THE LEAD TIP.
  - ⚠ TERMINAL NUMBERS ARE SHOWN FOR REFERENCE ONLY.

SYMBOL	MILLIMETERS			NOTE
	MINIMUM	NOMINAL	MAXIMUM	
A	1.40	1.50	1.60	
A1	0.00	—	0.10	
b	0.38	0.42	0.48	
b1	0.48	0.52	0.58	
b2	1.79	1.82	1.87	
c	0.40	0.42	0.46	
D	4.40	4.50	4.70	2,3
E	3.70	4.00	4.30	
E1	2.40	2.50	2.70	2,3
E2	0.80	1.00	1.20	
E3	0.40	0.50	0.60	
e	1.50 TYP.			
φ	4° TYP.			
R	0.15 TYP.			
R1	—	—	0.20	
SYMBOL	TOLERANCES OF FORM AND POSITION		NOTE	
aaa	0.15			
bbb	0.20			
ccc	0.10			
ddd	0.10			

### Suggested PCB Land Pattern and PAD Layout

PCB Land Pattern

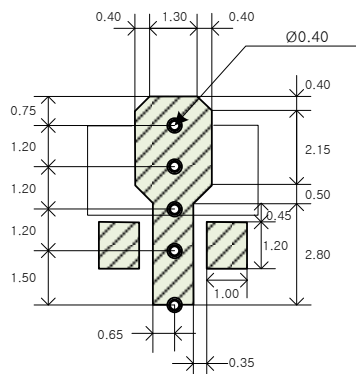

Note : All dimension are in millimeters

PCB lay out \_ on BeRex website

PCB Mounting

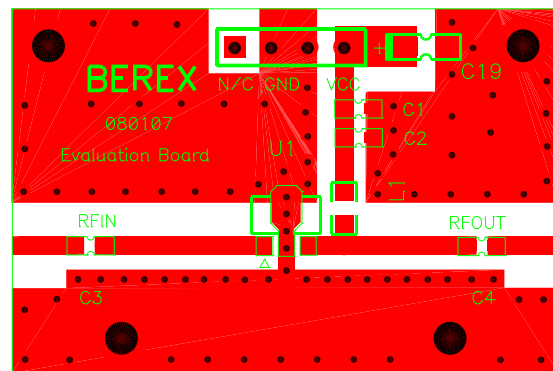

# BT013

1500-4000 MHz Medium Power Amplifier



## Package Marking

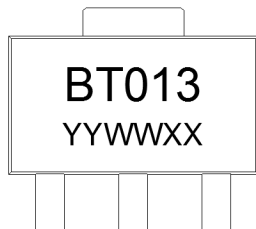

Pin 1

YY = Year, WW = Working Week,  
XX = Wafer No.

## Tape & Reel

SOT89

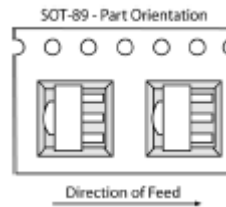

Packaging information:

Tape Width (mm): 12  
Reel Size (inches): 7  
Device Cavity Pitch (mm): 8  
Devices Per Reel: 1000

## Lead plating finish

100% Tin Matte finish

(All BeRex products undergoes a 1 hour, 150 degree C, Anneal bake to eliminate thin whisker growth concerns.)

## MSL / ESD Rating

<b>ESD Rating:</b>	Class 1B
<b>Value:</b>	Passes <1000V
<b>Test:</b>	Human Body Model (HBM)
<b>Standard:</b>	JEDEC Standard JESD22-A114B
<b>MSL Rating:</b>	Level 1 at +265°C convection reflow
<b>Standard:</b>	JEDEC Standard J-STD-020

## NATO CAGE code:

2	N	9	6	F
---	---	---	---	---