



# TAI-SAW TECHNOLOGY CO., LTD.

No. 3, Industrial 2nd Rd., Ping-Chen Industrial District,  
Taoyuan, 324, Taiwan, R.O.C.

TEL: 886-3-4690038 FAX: 886-3-4697532

E-mail: [tstsales@mail.taisaw.com](mailto:tstsales@mail.taisaw.com) Web: [www.taisaw.com](http://www.taisaw.com)

## Approval Sheet For Product Specification

Issued Date: Apr, 24, 2009

Product Name: SAW Filter 707 MHz SMD 3.8X3.8 mm

TST Parts No.: TA1015A

Customer Parts No.: \_\_\_\_\_

Company: _____
Division: _____
Approved by : _____
Date: _____

Checked by: \_\_\_\_\_ Bob Chau *Bob Chau*

Approval by: \_\_\_\_\_ Francis Chen 

Date: \_\_\_\_\_ 4, 24, 2009



# TAI-SAW TECHNOLOGY CO., LTD.

No. 3, Industrial 2nd Rd., Ping-Chen Industrial District,  
Taoyuan, 324, Taiwan, R.O.C.

TEL: 886-3-4690038 FAX: 886-3-4697532

E-mail: [tstsales@mail.taisaw.com](mailto:tstsales@mail.taisaw.com) Web: [www.taisaw.com](http://www.taisaw.com)

## SAW Filter 707 MHz

MODEL NO.:TA1015A

REV. NO.:1

### A. MAXIMUM RATING:

1. Input Power Level: 10 dBm
2. DC Voltage : 3V
3. Operating Temperature: -30°C to +85°C
4. Storage Temperature: -40°C to +85°C

RoHS Compliant  
Lead free  
Lead-free soldering

### B. ELECTRICAL CHARACTERISTICS:

Item	Unit	Min.	Typ.	Max.	Note
Center Frequency <b>Fc</b>	MHz	-	707	-	-
Insertion loss (697~717 MHz) <b>IL</b>	dB	-	2.3	4	-
Bandwidth	MHz	20	28.5	-	-
Amplitude Ripple (697 ~ 717 MHz)	dB	-	0.8	1.4	-
<b>Attenuation</b> (Reference level from 0 dB)					
300 ~ 600 MHz	dB	28	56	-	-
728 ~ 757 MHz	dB	10	17	-	-
800 ~ 1050 MHz	dB	28	52	-	-
Temperature Coefficient of Frequency	Ppm/°C	-	-36	-	-

### C. MEASUREMENT CIRCUIT:

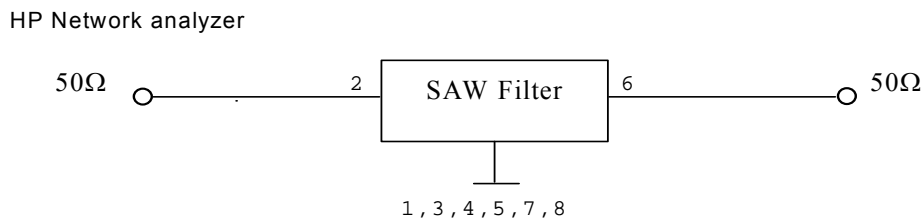

**D.OUTLINE DRAWING:**

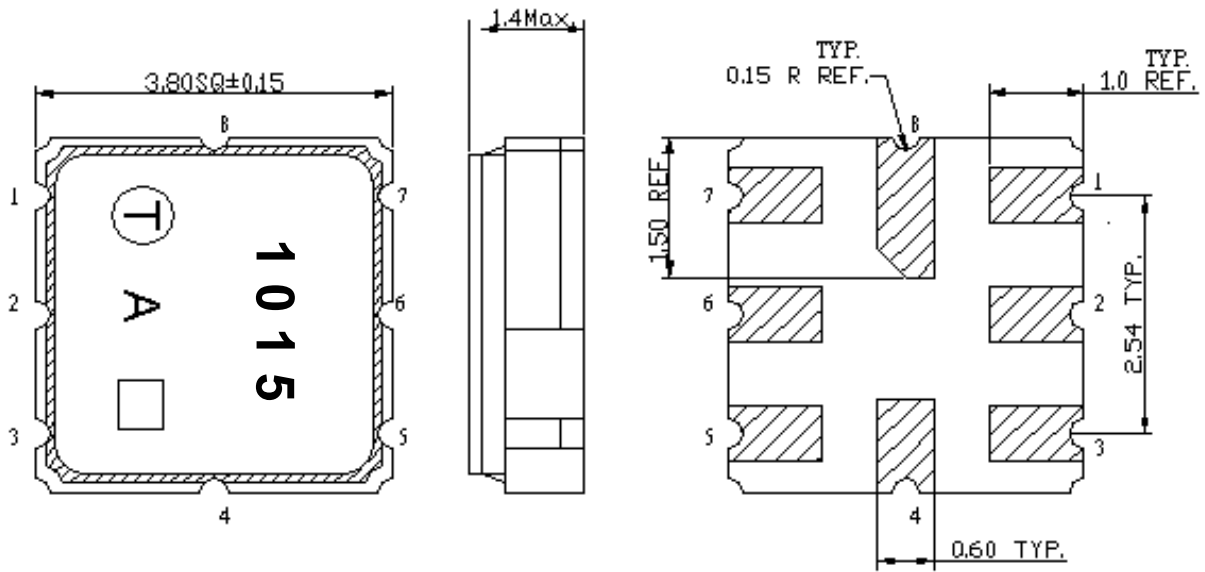

- 2 : Input
- 6: Output
- 1,3,4,5,7,8: Ground
- : Date Code (W01->A, W02->B,...W52->z)
- Unit: mm

**E. PCB Footprint:**

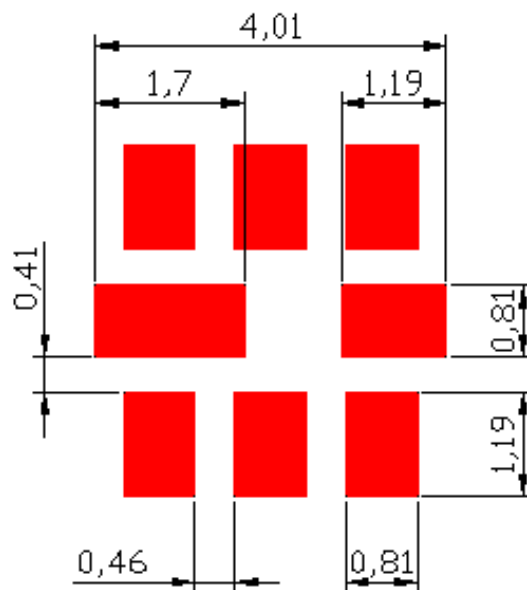

## F. Frequency Characteristics :

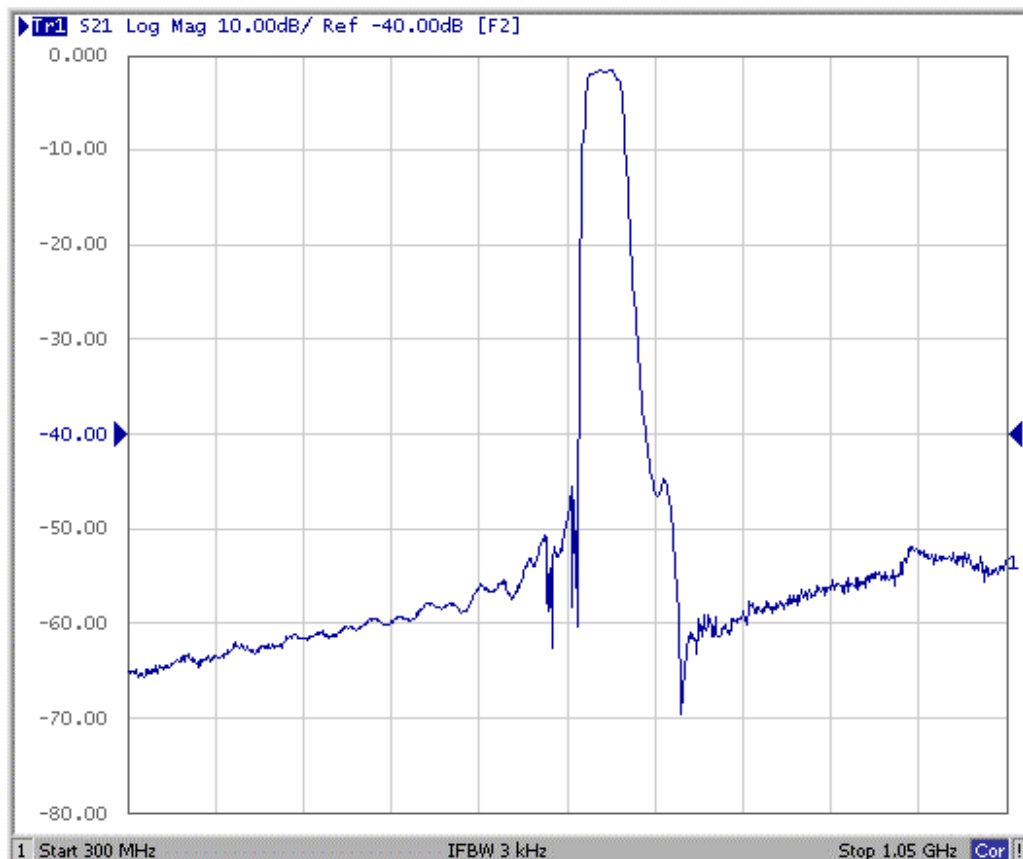
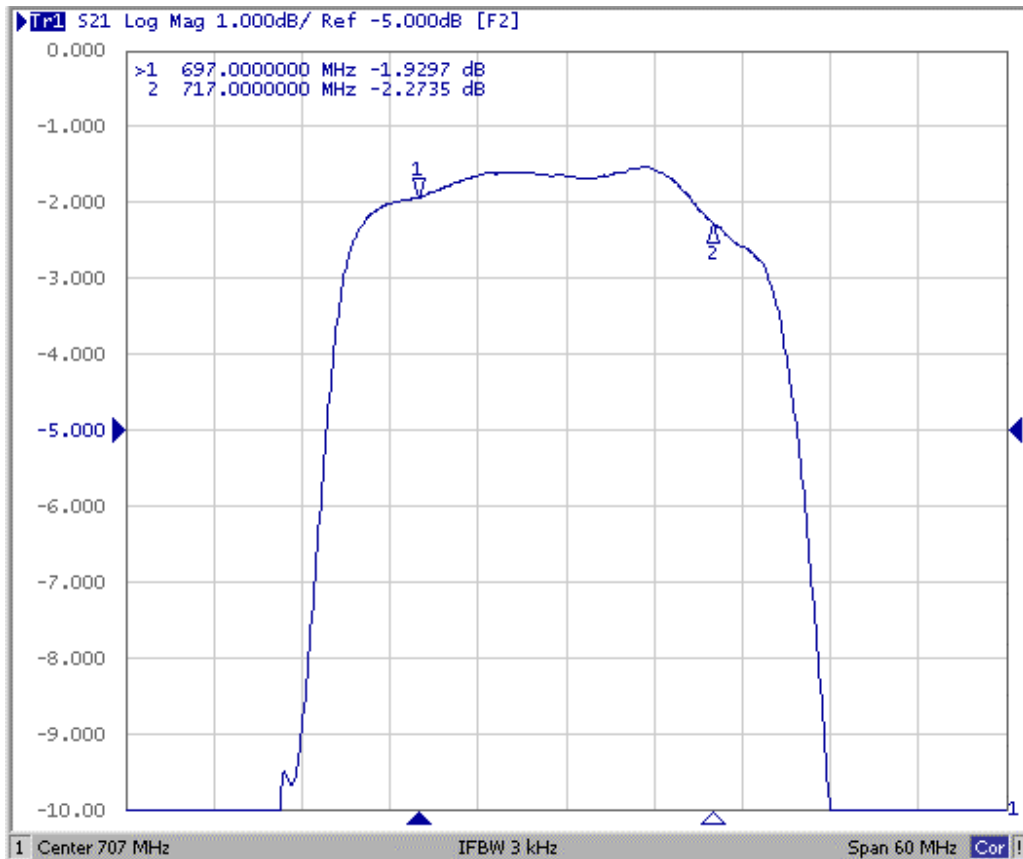

**G. PACKING:**

**1. REEL DIMENSION**

(Reel Count : 7"=1000 ; 13"=3000 )

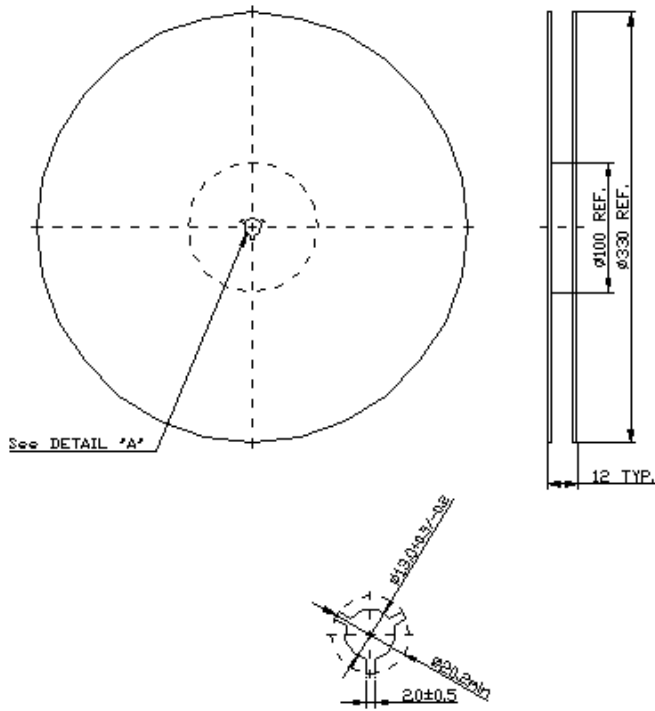

**2.TAPE DIMENSION**

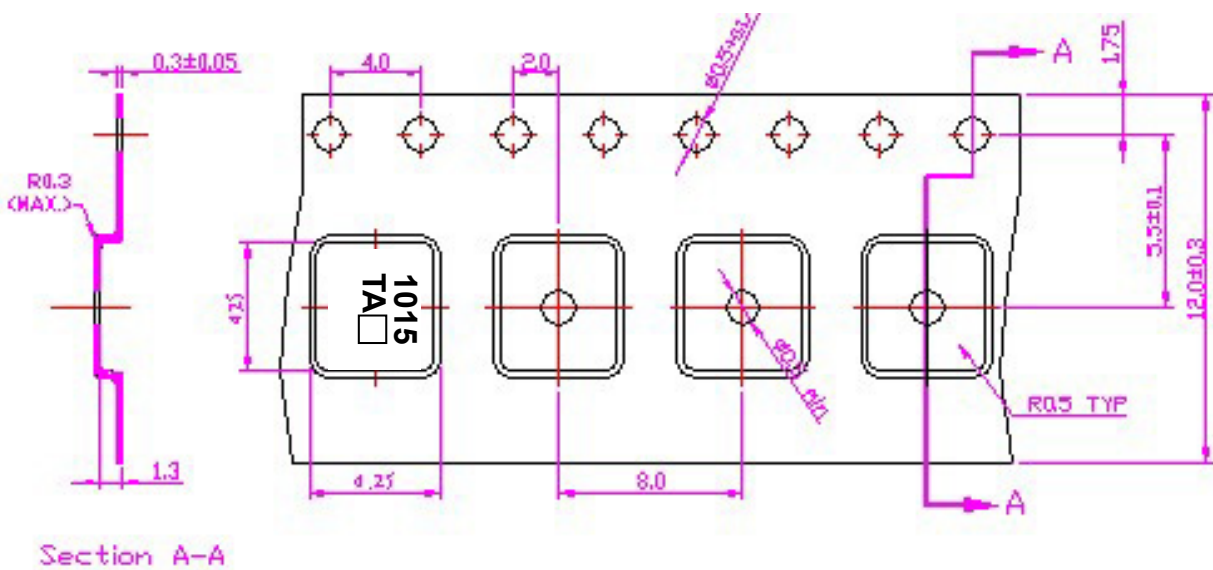

Section A-A

**Direction of Feed**

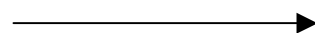

**H. RECOMMENDED REFLOW PROFILE :**

