

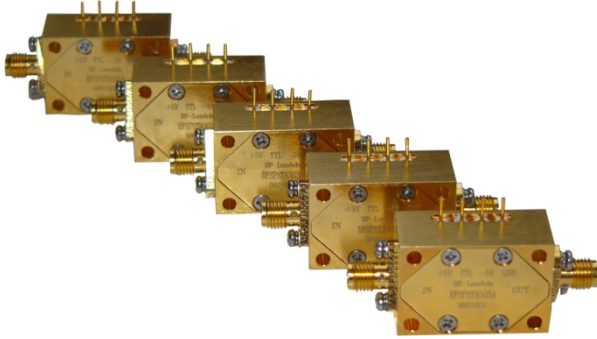

Absorptive and Reflective 1-2GHz Coaxial SPST



Features

- Wide Band Operation 1-2GHz
- High Power Handle Capability up to 50W upon request.
- TTL compatible driver include
- Fast Switching Speed
- Low Insertion Loss and High Isolation
- Temperature Range -40°C~+85°C
- Customization available upon request

Absorptive SPST- Single Pole Single Throw						
Part Number	Frequency (GHz)	Insert. Loss (dB)	VSWR (Max:1)	Isolation min (dB)	Power (Watts)	Switching Speed (ns)
RFSPSTA0102G	1-2	1.0	1.5	80	0.2W opt. 1W max.	50~100
Reflective SPST- Single Pole Single Throw						
Part Number	Frequency (GHz)	Insert. Loss (dB)	VSWR (Max:1)	Isolation min (dB)	Power (Watts)	Switching Speed (ns)
RFSPSTR0102G	1-2	0.8	1.5	80	0.5~50	100~500

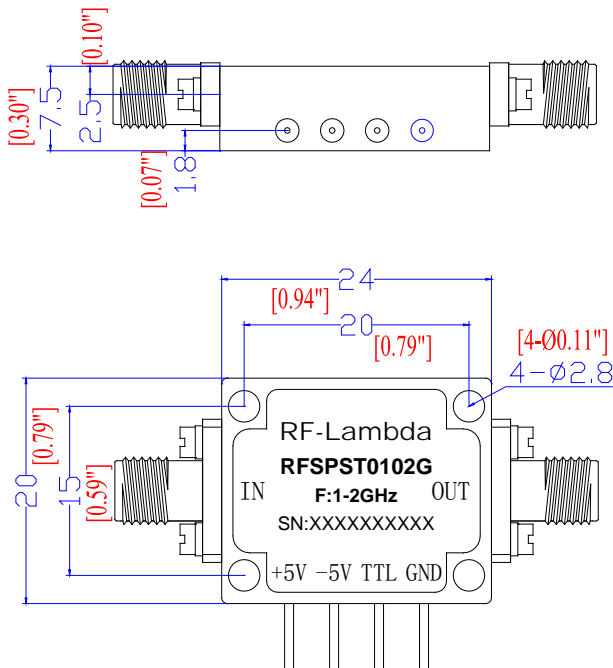

Mechanical Specification

- Finishing: Gold plating for brass material
Other finishing available
- Connector: SMA-F Per MIL-C-39012
- Control PIN: 0.02" dia x 0.15" solder pins
- Weight: 20 grams max.
- Mounting: (4 / 6) 0.1" dia through holes

Electrical Operation

- DC Biasing:
+5.0V (+/-0.5V 30mA max.)
-5.0V (+/-0.5V 30mA max.)
High Voltage Biasing is required for high RF power model.

- TTL Logic Control:
0 OFF
1 Jo->J1

Power Handle: 0.2W~50W (upon request)

Note: Contact RF-Lambda for faster switching speed, higher power handle, higher isolation

- 1.Higher power handle capability will give lower isolation , higher biasing current and slower switching speed.
- 2.Narrower frequency band will improve insertion loss and isolation.



RF-LAMBDA

The power beyond expectations

1-2GHz PIN SPST

Absorptive / Reflective Coaxial Single Pole Single Throw Switch 1-2GHz

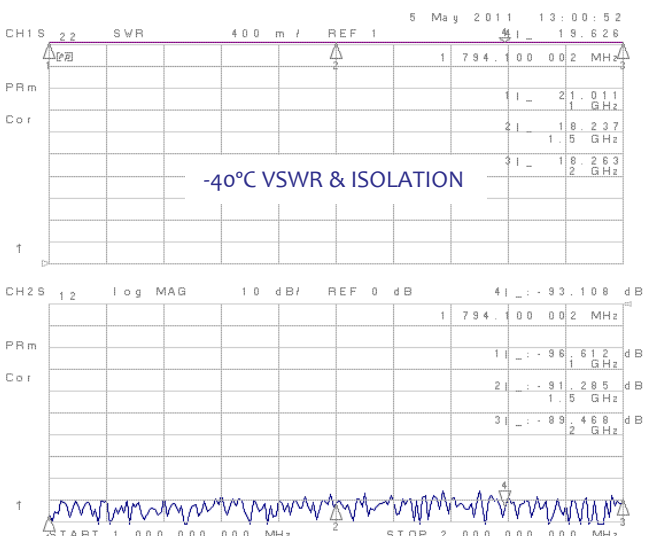
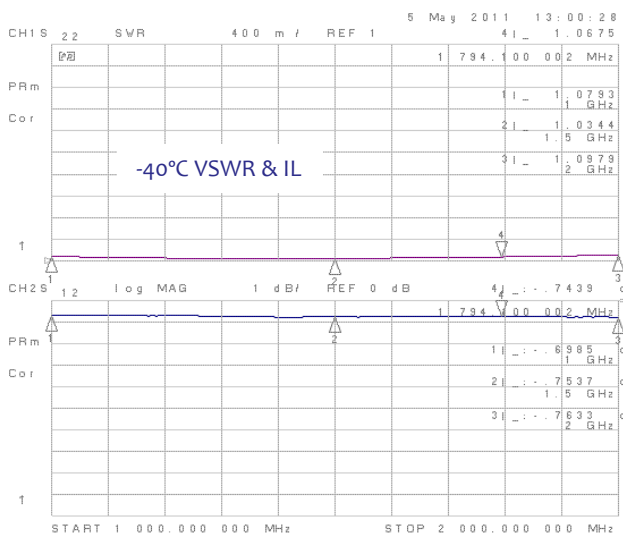
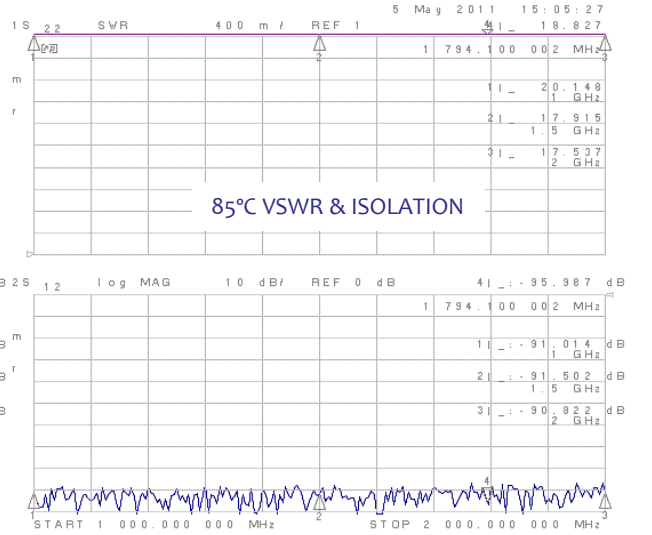
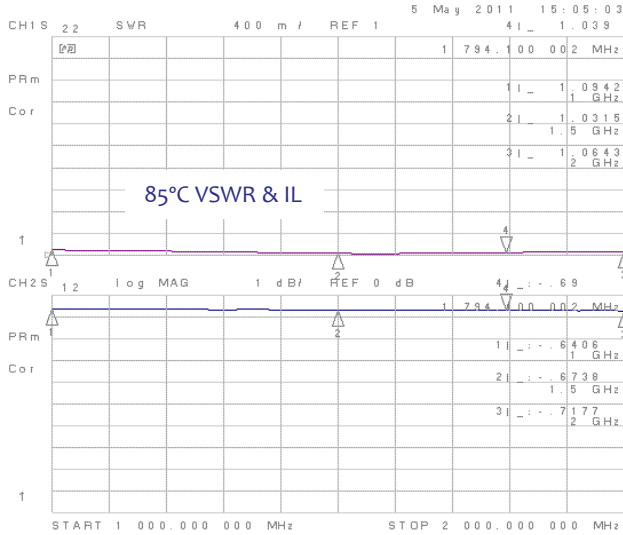
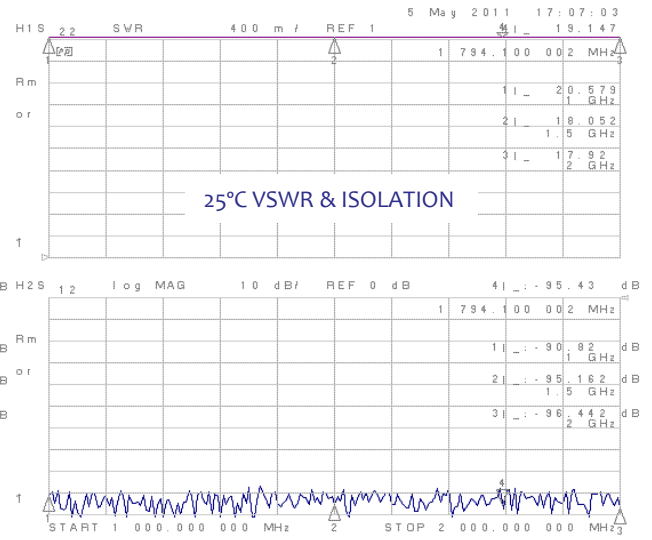
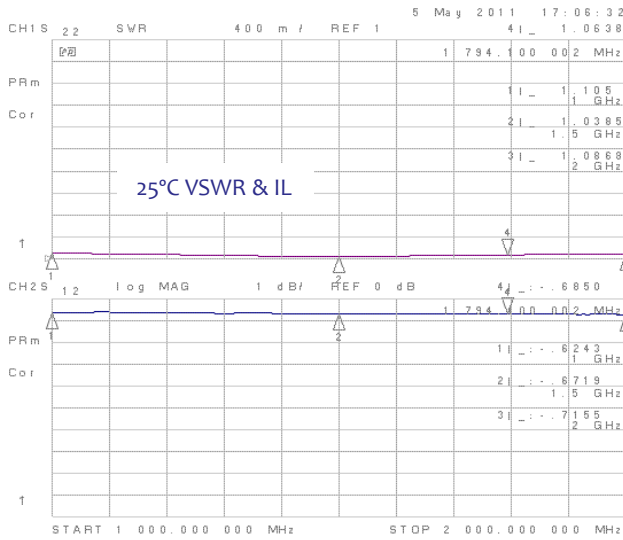



RF-LAMBDA

The power beyond expectations

1-2GHz PIN SPST

Absorptive / Reflective Coaxial Single Pole Single Throw Switch 1-2GHz

