

# Surface Mount Power Splitter/Combiner

2 Way-0° 50Ω

1420 to 1660 MHz

BP2G+



CASE STYLE: XX211

## Maximum Ratings

Operating Temperature	-40°C to 85°C
Storage Temperature	-65°C to 150°C
Power Input (as a splitter)	1.5W max.
Internal Dissipation	0.75W max.

Permanent damage may occur if any of these limits are exceeded.

## Pin Connections

SUM PORT	2
PORT 1	8
PORT 2	5
GROUND	1,3,4,6,7

## Features

- low insertion loss, 0.4 dB typ.
- high isolation, 28 dB typ.
- good output VSWR, 1.15:1 typ.
- good input VSWR, 1.2:1 typ.
- excellent power handling, 1.5W
- low profile, 0.077"

## Applications

- GPS
- PDC
- mobile satellite
- defense & aeronautical

**+RoHS Compliant**  
The +Suffix identifies RoHS Compliance. See our web site for RoHS Compliance methodologies and qualifications

**Available Tape and Reel at no extra cost**  
Reel Size Devices/Reel  
7" 20, 50, 100, 200, 500, 1000

## Electrical Specifications

FREQ. RANGE (MHz)	ISOLATION (dB)		INSERTION LOSS (dB) ABOVE 3.0 dB		PHASE UNBALANCE (Degrees)	AMPLITUDE UNBALANCE (dB)	VSWR (:1)	
	Typ.	Min.*	Typ.	Max.			S-Port Typ.	Output Ports Typ.
1420-1660	28	20	0.6	1.0	3.0	0.2	1.15	1.15

\* 17 dB over 1420-1500 MHz

## Typical Performance Data at 25°C

Frequency (MHz)	Total Loss <sup>1</sup> (dB)		Amplitude Unbalance (dB)	Isolation (dB)	Phase Unbalance (deg.)	VSWR S	VSWR 1	VSWR 2
	S-1	S-2						
1420.00	3.30	3.23	0.07	18.76	0.46	1.09	1.18	1.17
1440.00	3.30	3.23	0.07	19.68	0.47	1.08	1.17	1.16
1460.00	3.30	3.24	0.06	20.71	0.51	1.08	1.16	1.15
1480.00	3.31	3.24	0.07	21.88	0.52	1.08	1.16	1.15
1500.00	3.32	3.24	0.08	23.24	0.54	1.09	1.16	1.14
1520.00	3.32	3.25	0.07	24.76	0.55	1.11	1.16	1.14
1540.00	3.33	3.25	0.08	26.62	0.59	1.13	1.16	1.14
1560.00	3.34	3.26	0.08	28.87	0.60	1.15	1.17	1.15
1580.00	3.35	3.27	0.08	31.75	0.64	1.17	1.18	1.16
1600.00	3.36	3.28	0.08	35.01	0.66	1.20	1.20	1.17
1620.00	3.37	3.29	0.08	36.48	0.68	1.23	1.21	1.18
1640.00	3.39	3.30	0.09	33.93	0.71	1.25	1.23	1.20
1660.00	3.41	3.32	0.09	30.75	0.74	1.28	1.25	1.22

1. Total Loss = Insertion Loss + 3dB splitter loss.

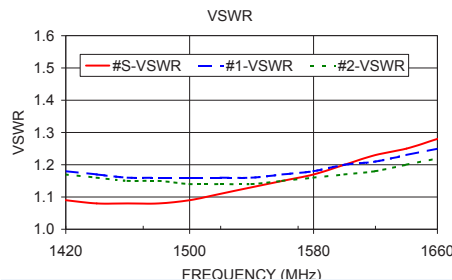
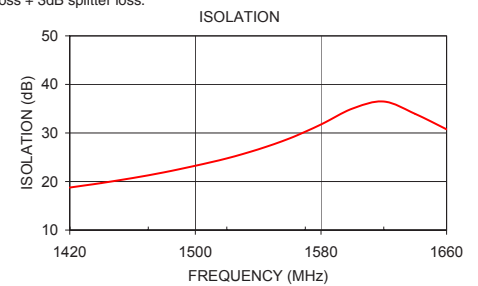
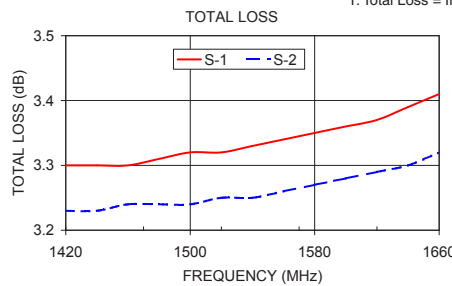

## electrical schematic



## Outline Drawing

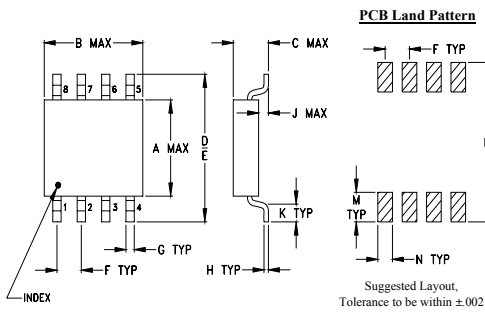

## Outline Dimensions (inch/mm)

A	B	C	D	E	F	G
.163	.210	.077	.250	.220	.050	.017
4.14	5.33	1.96	6.35	5.59	1.27	0.43

H	J	K	M	N	P	wt
.009	.025	.030	.050	.030	.270	grams
0.23	0.64	0.76	1.27	0.76	6.86	0.10

## Demo Board MCL P/N: TB-37 Suggested PCB Layout (PL-053)

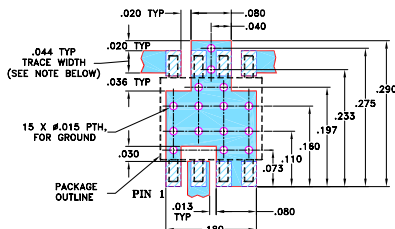

- NOTES: 1. TRACE WIDTH IS SHOWN FOR ROGERS RO4350B WITH DIELECTRIC THICKNESS 0.020" ± 0.0015", COPPER: 1/2 OZ. EACH SIDE. FOR OTHER MATERIALS TRACE WIDTH MAY NEED TO BE MODIFIED.  
2. BOTTOM SIDE OF THE PCB IS CONTINUOUS GROUND PLANE.
- DENOTES PCB COPPER LAYOUT WITH SMOBC (SOLDER MASK OVER BARE COPPER)
  - ▨ DENOTES COPPER LAND PATTERN FREE OF SOLDER MASK

## ESD Rating

Human Body Model (HBM): Class 1A (250 v to <500 v) in accordance with ANSI/ESD STM 5.1 - 2001  
Machine Model (MM): Class M1 (< 100 v) in accordance with ANSI/ESD STM 5.2 - 1999 (pass 50V)

## Notes

- A. Performance and quality attributes and conditions not expressly stated in this specification document are intended to be excluded and do not form a part of this specification document.  
B. Electrical specifications and performance data contained in this specification document are based on Mini-Circuit's applicable established test performance criteria and measurement instructions.  
C. The parts covered by this specification document are subject to Mini-Circuits standard limited warranty and terms and conditions (collectively, "Standard Terms"); Purchasers of this part are entitled to the rights and benefits contained therein. For a full statement of the Standard Terms and the exclusive rights and remedies thereunder, please visit Mini-Circuits' website at [www.minicircuits.com/MCLStore/terms.jsp](http://www.minicircuits.com/MCLStore/terms.jsp)

