



Absorptive / Reflective 4-8GHz SP8T Switch



- Wide Band Operation 4-8GHz
- High Power Handle Capability from 0.2W CW to 30W upon request.
- TTL compatible driver include
- Fast Switching Speed
- Low Insertion Loss and High Isolation
- Temperature Range -45°C~+85°C
- Customization available upon request

Absorptive SP8T- Single Pole Eight Throw						
Part Number	Frequency (GHz)	Insert. Loss (dB)	VSWR (Max:1)	Isolation min (dB)	Avg. Power (Watts)	Switching Speed (ns)
RFSP8TA0408G	4-8	2.0	2.8	65	0.2~1	100~500
Reflective SP8T- Single Pole Eight Throw						
Part Number	Frequency (GHz)	Insert. Loss (dB)	VSWR (Max:1)	Isolation min (dB)	Avg. Power (Watts)	Switching Speed (us)
RFSP8TR0408G	4-8	2.0	1.8	65	1~30	0.5~10

Environment specifications	
Altitude	45000 ft
Vibration	10g rms (15 degree 2KHz)
Humidity	100% RH at 35c, 95%RH at 40 degc
Shock	20G for 11msec
PIN define	PIN 1:+5V PIN 2:-5V PIN 3: GND PIN 4:C1 PIN 5:C2 PIN 6:C3 PIN 7,8,9 N/A

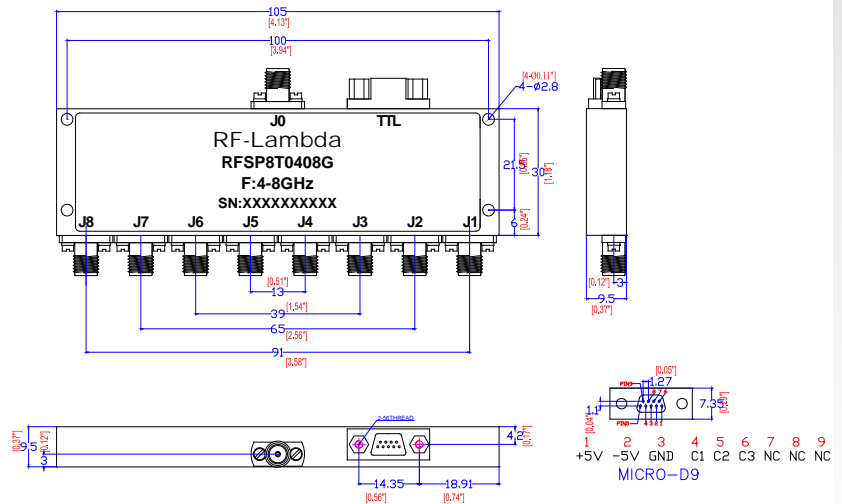

Control Signal	ON
C8C7C6C5C4C3 C2 C1: 00000001	Jo-J1
C8C7C6C5C4C3 C2 C1: 00000010	Jo-J2
C8C7C6C5C4C3 C2 C1: 00000100	Jo-J3
C8C7C6C5C4C3 C2 C1: 00001000	Jo-J4
C8C7C6C5C4C3 C2 C1: 00010000	Jo-J5
C8C7C6C5C4C3 C2 C1: 00100000	Jo-J6
C8C7C6C5C4C3 C2 C1: 01000000	Jo-J7
C8C7C6C5C4C3 C2 C1: 10000000	Jo-J8

Absorptive / Reflective Coaxial Single Pole Eight Throw Switch 4-8GHz



RF-LAMBDA

The power beyond expectations

4-8GHz PIN SP8T

Ports	Function
J1	OUTPUT1
J2	OUTPUT2
J3	OUTPUT3
J4	OUTPUT4
J5	OUTPUT5
J6	OUTPUT6
J7	OUTPUT7
J8	OUTPUT8
Jo	INPUT

PIN	1	2	3	4	5	6	7
Function	+5V	-5V	GND	C1	C2	C3	C4
PIN	8	9	10	11	12-15		
Function	C5	C6	C7	C8	N/A		

Biasing: -5V(Max, 70mA Typical 30mA)
+5V(Max, 350mA Typical 250mA)

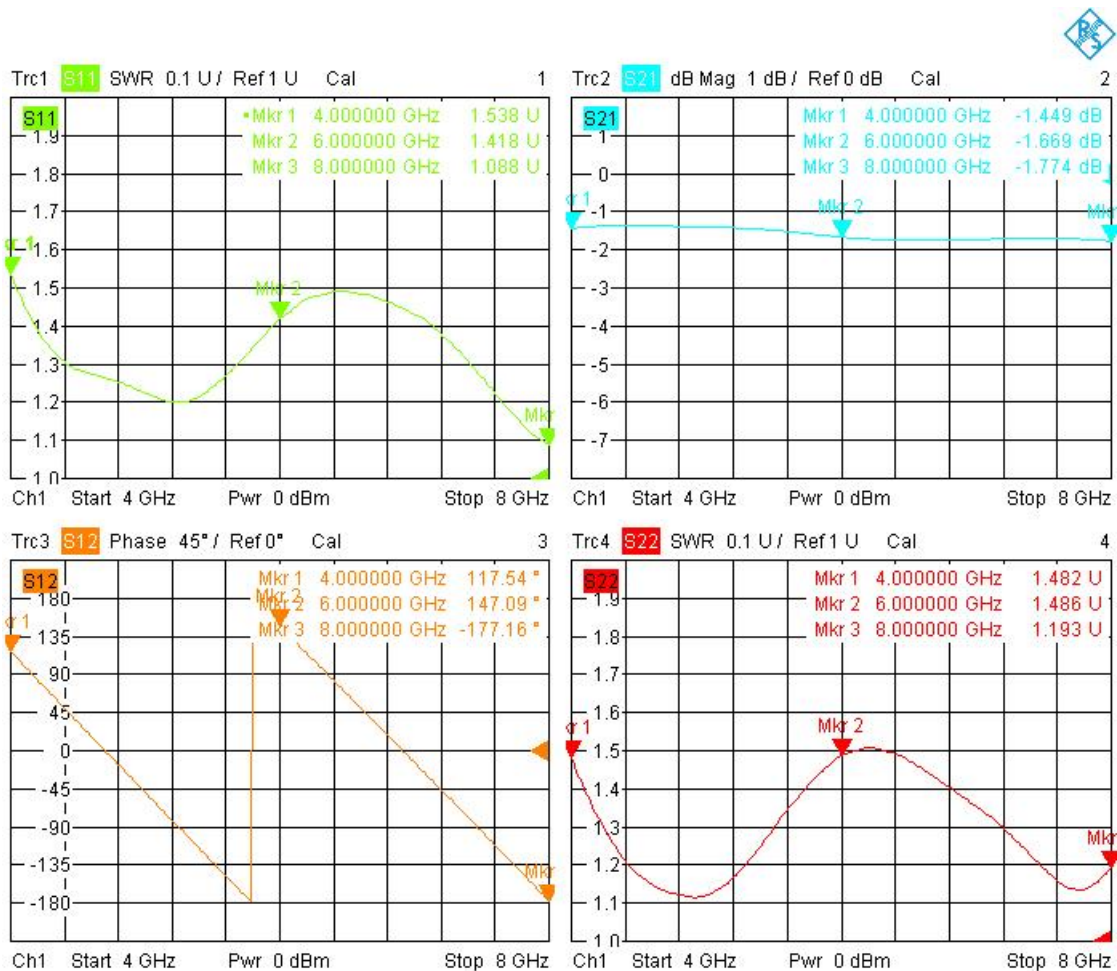

4/28/2009, 4:33 PM

Absorptive / Reflective Coaxial Single Pole Eight Throw Switch 4-8GHz



RF-LAMBDA

The power beyond expectations

4-8GHz PIN SP8T

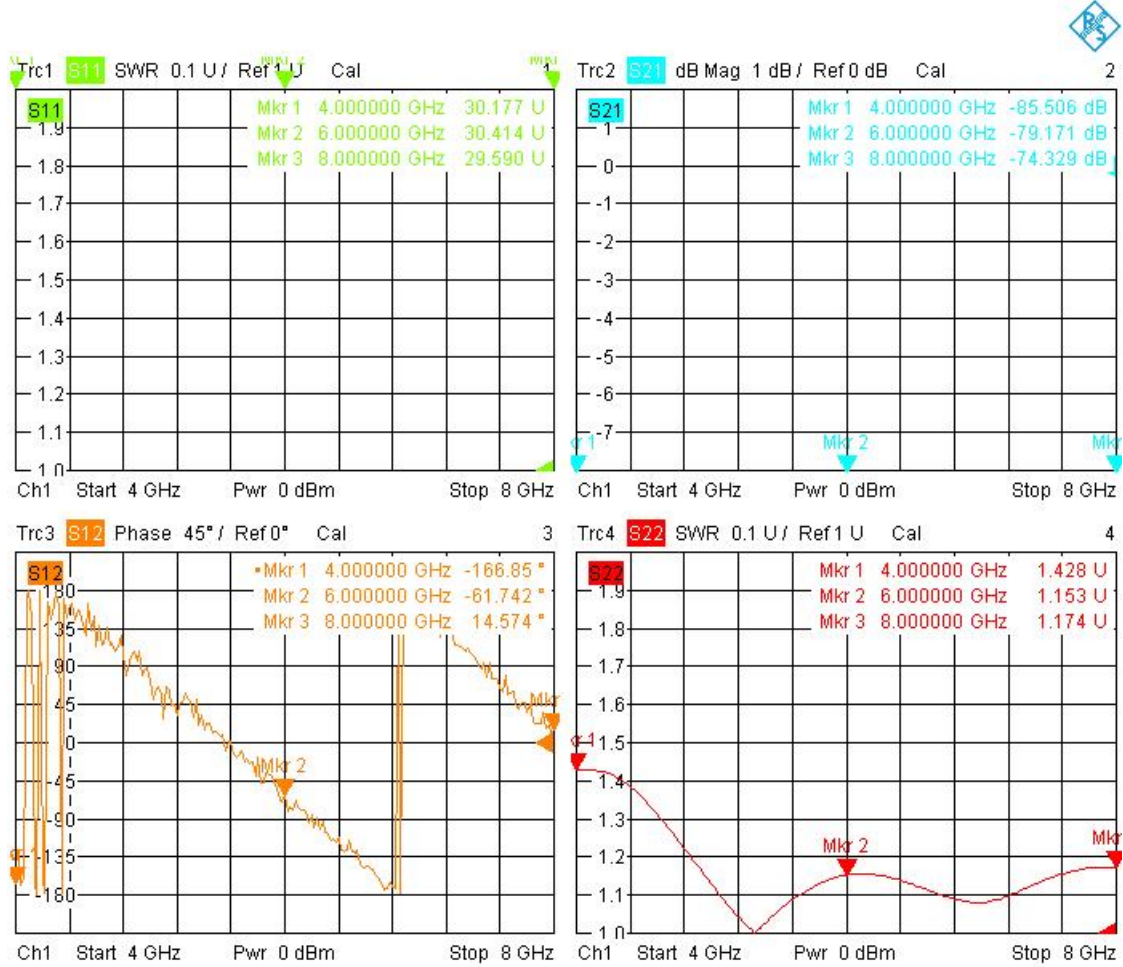

4/28/2009, 5:51 PM

Absorptive / Reflective Coaxial Single Pole Eight Throw Switch 4-8GHz