



75 Ohm SMC Jack Connector Clamp/Solder Attachment For RG180, RG195

TECHNICAL DATA SHEET

PE4275

75 Ohm SMC Jack Connector Clamp/Solder Attachment For RG180, RG195

Configuration

Connector	SMC Jack
Connector Interface Type	RG180, RG195
Cable Attachment Method (Shield/Contact)	Clamp/Solder
Body Style	Straight

Electrical Specifications

Impedance, Ohms	75
-----------------	----

Mechanical Specifications

Size

Length, in [mm]	0.725 [18.42]
Width/Dia., in [mm]	0.345 [8.76]
Weight, lbs [g]	0.013 [5.9]

Connector

Type	SMC Jack
Contact Material and Plating	Gold
Body Material and Plating	Brass, Nickel
Dielectric Type	PTFE

Compliance Certifications (visit www.Pasternack.com for current document)

RoHS Compliant	Yes
----------------	-----

Plotted and Other Data

Notes:	Values at 25 °C, sea level
--------	----------------------------

75 Ohm SMC Jack Connector Clamp/Solder Attachment For RG180, RG195 from Pasternack Enterprises has same day shipment for domestic and International orders. Our RF, microwave and fiber optic products maintain a 99% availability and are part of the broadest selection in the industry.

Click the following link (or enter part number in "SEARCH" on website) to obtain additional part information including price, inventory and certifications: [75 Ohm SMC Jack Connector Clamp/Solder Attachment For RG180, RG195 PE4275](http://www.pasternack.com/smc-jack-standard-rg180-rg195-connector-pe4275-p.aspx)

URL: <http://www.pasternack.com/smc-jack-standard-rg180-rg195-connector-pe4275-p.aspx>

The information contained in this document is accurate to the best of our knowledge and representative of the part described herein. It may be necessary to make modifications to the part and/or the documentation of the part, in order to implement improvements. Pasternack reserves the right to make such changes as required. Unless otherwise stated, all specifications are nominal.



PE4275 CAD Drawing

75 Ohm SMC Jack Connector Clamp/Solder Attachment For RG180, RG195

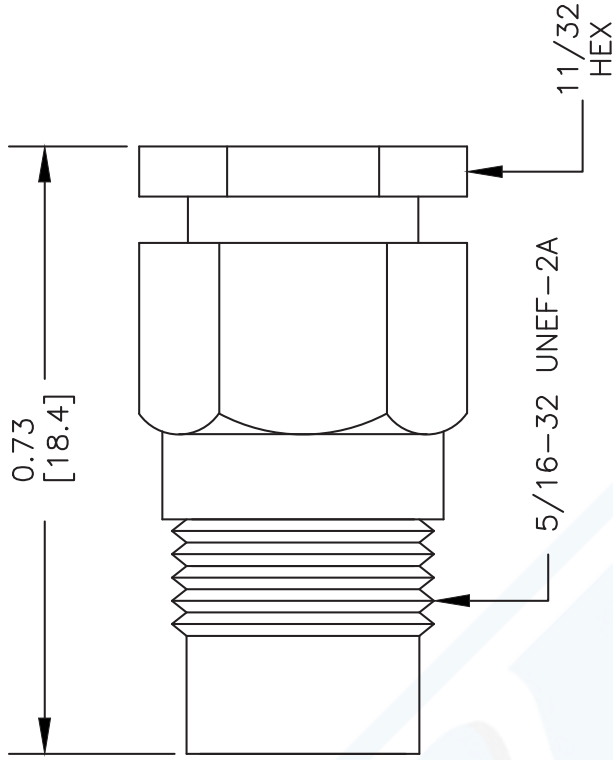
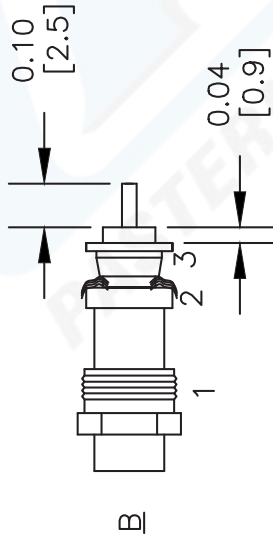
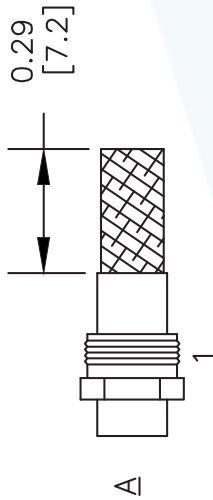
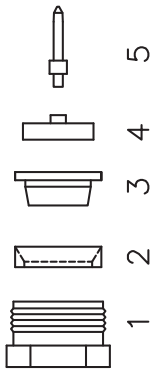

STRIPPING DIMENSIONS

ASSEMBLY PROCEDURES

1. SLIDE CLAMP NUT (1) OVER CABLE AS SHOWN IN A. SLIDE COMPRESSION WASHER (2) OVER BRAID & SEAT AGAINST JACKET. FLAIR BRAID OVER COMPRESSION WASHER (2).
2. SLIDE BRAID CLAMP (3) OVER DIELECTRIC & UNDER BRAID. PUSH INTO WASHER UNTIL IT STOPS. STRIP CABLE AS SHOWN IN B. TRIM EXCESS BRAID FLUSH WITH SURFACE OF COMPRESSION WASHER (2). INSERT INSULATOR (4) OVER DIELECTRIC WITH CENTER CONDUCTOR PROTRUDING THROUGH HOLE.
3. SOLDER CONTACT (5) TO CENTER CONDUCTOR. INSERT CABLE ASSEMBLY INTO BODY & TIGHTEN.



Pasternack Enterprises, Inc.
 P.O. Box 16759 | Irvine | CA | 92623
 Phone: (949) 261-1920 | Fax: (949) 261-7451
 Website: www.pasternack.com | E-Mail: sales@pasternack.com

DWG TITLE

PE4275

NOTES:
 1. UNLESS OTHERWISE SPECIFIED ALL DIMENSIONS ARE NOMINAL.
 2. ALL SPECIFICATIONS ARE SUBJECT TO CHANGE WITHOUT NOTICE AT ANY TIME.
 3. DIMENSIONS ARE IN INCHES [mm].
 4. FITS MIL-C-17 AND EQUIVALENT CABLES.

REV. -

FSCM NO. 53919

CAD FILE 042309

SCALE N/A

SIZE A

2233