

Helping Customers Innovate, Improve & Grow



Features

- 4-Pin Dip
- Fast Warm-up
- Frequency Range: 80 MHz to 120 MHz
- Low g-sensitivity
- Low Phase Noise

Applications

- Base Stations
- Test Equipment
- Synthesizers
- Military Communication Equipment

Performance Specifications

Frequency Stabilities ¹ (SC-Cut Crystal-Option)					
Parameter	Min	Typical	Max	Unit	Condition
vs. operating temperature range (referenced to +25°C)	-200		+200	ppb	-40 to +85°C
	-150		+150	ppb	-20 to +70°C
	-100		+100	ppb	-0 to +70°C
	-50		+50	ppb	-40 to +85°C (height code 0 and 3 only)
	-35		+35	ppb	-20 to +70°C (height code 0 and 3 only)
	-25		+25	ppb	-0 to +70°C (height code 0 and 3 only)
Initial tolerance vs. supply voltage change	-0.2		+0.2	ppm	at time of shipment, nominal EFC
	-50		+50	ppb	V _s ±5% static (CMOS outputs)
	-25		+25	ppb	V _s ±5% static (sine outputs)
	-10		+10	ppb	Load ±5% static
vs. load change	-3		+3	ppb	after 30 days of operation
vs. aging/day	-300		+300	ppb	after 30 days of operation
Warm-up time			2	minutes	to ±100ppb of final frequency (1 hour reading) @ +25°C

Performance Specifications

Supply Voltage (Vs)						
Parameter	Min	Typical	Max	Unit	Condition	
Supply Voltage	4.75	5.0	5.25	VDC		
	3.165	3.3	3.465	VDC		
Power Consumption			3.5 4.5 1.0	Watts Watts Watts	during warm-up (5V versions) during warm-up (3V version) steady state @ +25°C	
RF Output						
Signal [Standard]	HCMOS					
Load		15		pF		
Signal Level (Vol)			0.5	VDC	with Vs=5V and 15 pF Load	
Signal Level (Voh)	4.7			VDC	with Vs=5V and 15 pF Load	
Signal Level (Vol)			0.3	VDC	with Vs=3.3V and 15 pF Load	
Signal Level (Voh)	3.0			VDC	with Vs=3.3V and 15 pF Load	
Duty Cycle	40		60	%	@ (Voh-Vol)/2	
	Sinewave (5V supply, height code 0 or 3 only)					
Load		50		Ω		
Output Power @ 5V	5	8	11	dBm	50 Ω load	
Harmonics			-40	dBm		
Frequency Tuning (EFC)						
Tuning Range	±1.0		±3.0	ppm		
Linearity			5	%		
Tuning Slope	Positive					
Control Voltage Range	0.0	2.0	4.0	VDC	5 V versions	
	0	1.5	3.0	VDC	3.3 V versions	
Additional Parameters						
Phase Noise ³			-95 -125 -145 -155 -160	dBc/Hz dBc/Hz dBc/Hz dBc/Hz dBc/Hz	10 Hz 100 Hz 1 kHz 10 kHz 100 kHz	@ 100MHz
G-Sensitivity			1 0.5	ppb/g ppb/g	worst direction - standard worst direction - request a custom part	
Weight			8	g		
Absolute Maximum Ratings						
Supply Voltage (Vs)			6.0	V		
Output Load			50	pF		
Operable Temperature Range	-55		+85	°C		
Environmental and Product Classification						
Shock (Endurance)	MIL-STD-202, Method 213, Condition J, 30 g 11 ms					
Sine Vibration (Endurance)	MIL-STD-202, Method 201 and 204, Condition A, except 5 g to 500 Hz, 1 sweep each axis					
Random Vibration (Endurance)	MIL-STD-202, Method 214, Condition I-D					
Humidity	MIL-STD-202, Method 103, Condition B, 100% rh					
Seal	MIL-STD-202, Method 112, Condition D					
Altitude	MIL-STD-202, Method 105, sea level to space					
Resistance to Soldering Heat	MIL-STD-202, Method 210, Condition A,B,C					
Terminal Strength	MIL-STD-202, Method 11, Condition C (5 bends at 45°, 2 lbs)					
Moisture Sensitivity level	1					
ROHS Compliant	Yes					
Storage Temperature Range	-55		+125	°C		

Outline Drawing / Enclosure

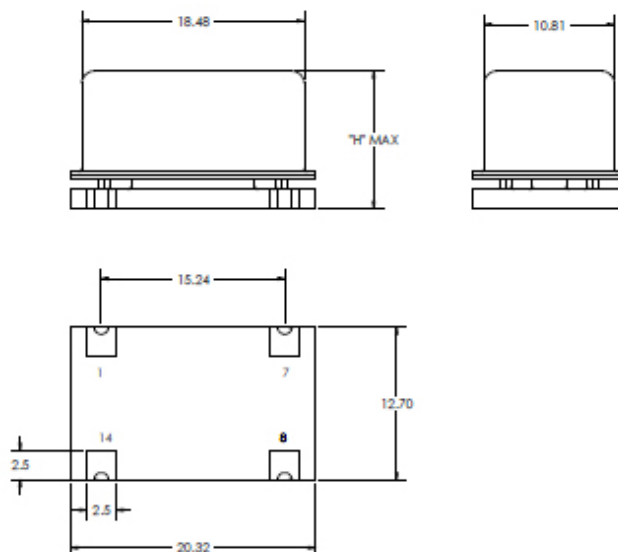
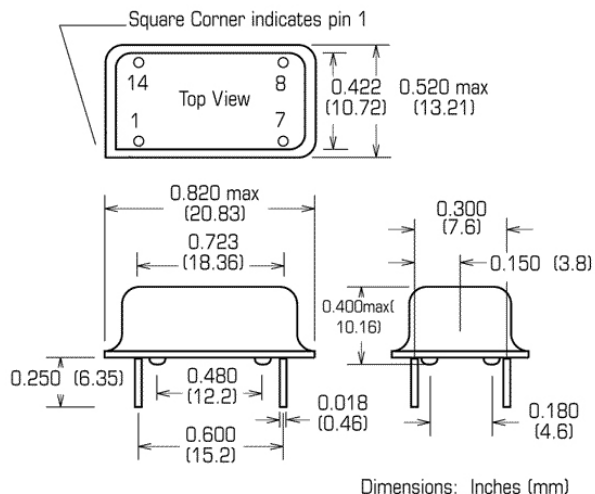

Dimensions in inches (mm)

Type A		
Code	Height "H"	Pin Length "L" Min
0	9.3	5.85
1	8.3	5.85
Pin Connections		
1	Electronic Frequency Control Input (EFC)	
7	Ground (Case)	
8	RF Output	
14	Supply Voltage Input (VS)	

Dimensions in mm

Type B		
Code	Height "H"	Pin Length "L" Min
2	10.4	NA
3	11.4	NA
Pin Connections		
1	Electronic Frequency Control Input (EFC)	
7	Ground (Case)	
8	RF Output	
14	Supply Voltage Input (VS)	

Standard Shipping Method

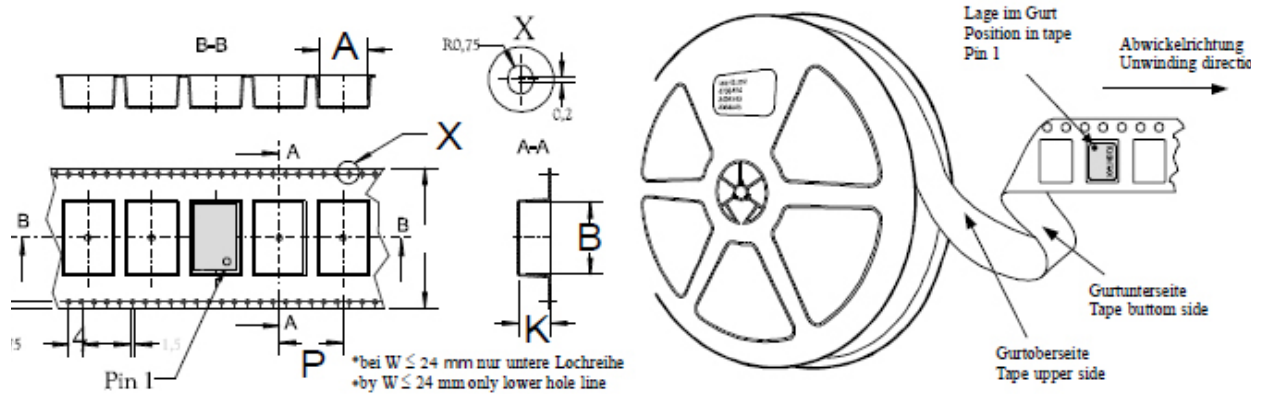

Enclosure Type	Tape width W [mm]	Quantity per meter	Quantity per reel	Dimension P
Type B	44	50	300	20

Recommended Reflow Profile

Solderprofile:

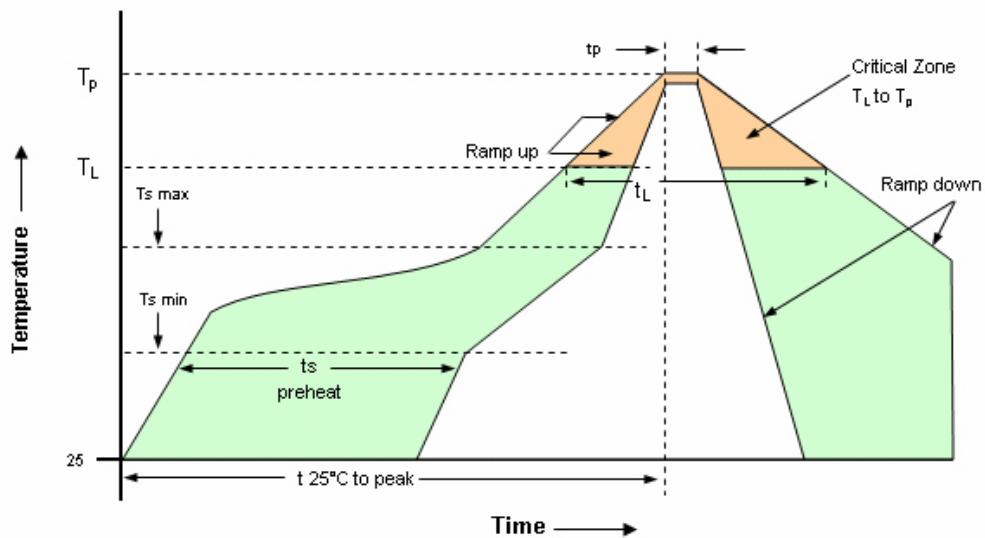

Profile Feature	Pb-Free Assembly /Sn-Pb Assembly	Profile Feature	Pb-Free Assembly /Sn-Pb Assembly
Average ramp-up rate (T_L to T_p)	3°C/second max.	Time 25°C to Peak Temperature	8 minutes max.
Preheat -Temperature Min T_{Smin} -Temperature Min T_{Smax} -Time (min to max) (t_s)	150°C 200°C 60-180 seconds	Time maintained above - Temperature (T_L) - Time (t_L)	217°C 60-150 seconds
T_{Smax} to T_L - Ramp-up Rate	3°C/second max.		
Time maintained above - Temperature (T_L) - Time (t_L)	217°C 60-150 seconds	Time within 5°C of actual Peak Temperature (t_p)	20-40 seconds
Peak Temperature (T_p)	max 260°C	Ramp-down Rate	6°C/second max.

Note: All temperatures refer to topside of the package, measured on the package body surface.

Ordering Information

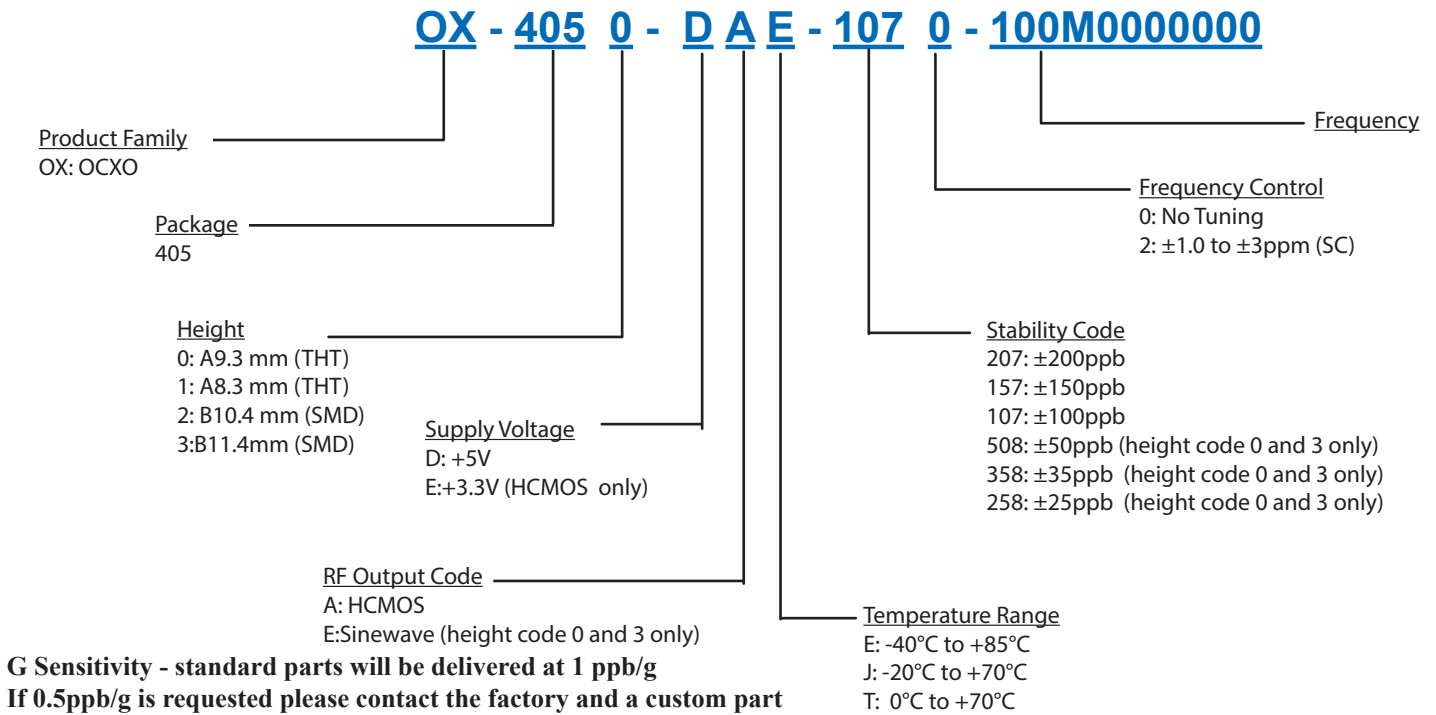

Notes:

1. Contact factory for improved stabilities or additional product options. Not all options and codes are available at all frequencies.
2. Unless other stated all values are valid after warm-up time and refer to typical conditions for supply voltage, frequency control voltage, load, temperature (25°C).
3. Phase noise degrades with increasing output frequency.
4. Subject to technical modification.
5. Contact factory for availability.

For Additional Information, Please Contact

USA:

Vectron International
267 Lowell Road, Suite 102
Hudson, NH 03051
Tel: 1.888.328.7661
Fax: 1.888.329.8328

Europe:

Vectron International
Landstrasse, D-74924
Neckarbischofsheim, Germany
Tel: +49 (0) 3328.4784.17
Fax: +49 (0) 3328.4784.30

Asia:

Vectron International
68 Yin Cheng Road(C), 22nd Floor
One LuJiaZui
Pudong, Shanghai 200120, China
Tel: +86 21 6194 6886
Fax: +86 21 6194 6699

Disclaimer

Vectron International reserves the right to make changes to the product(s) and or information contained herein without notice. No liability is assumed as a result of their use or application. No rights under any patent accompany the sale of any such product(s) or information.

Rev: 2-18-2014 jar