

Surface Mount Power Splitter/Combiner

JSPQ-350+ JSPQ-350

2 Way-90° 50Ω 150 to 350 MHz



CASE STYLE: BK276

Maximum Ratings

Operating Temperature	-40°C to 85°C
Storage Temperature	-55°C to 100°C
Power Input (as a splitter)	1W max.

Permanent damage may occur if any of these limits are exceeded.

Pin Connections

SUM PORT	1
PORT 1 (0°)	3
PORT 2 (+90°)	12
GROUND	5,7,8,10
50 OHM TERM. EXTERNAL	14
NOT USED	2,4,6,9,11,13

Outline Drawing

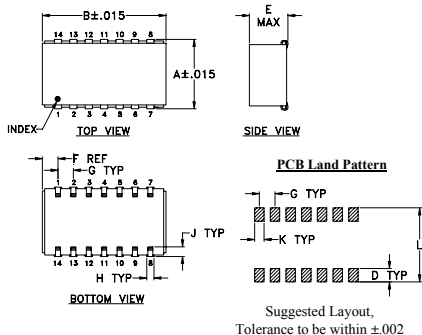

Outline Dimensions (inch/mm)

A	B	C	D	E	F	G
.450	.803	--	.100	.250	.102	.100
11.43	20.40	--	2.54	6.35	2.59	2.54

H	J	K	L	wt
.047	.065	.065	.470	grams
1.19	1.65	1.65	11.94	3.0

Demo Board MCL P/N: TB-59 Suggested PCB Layout (PL-061)

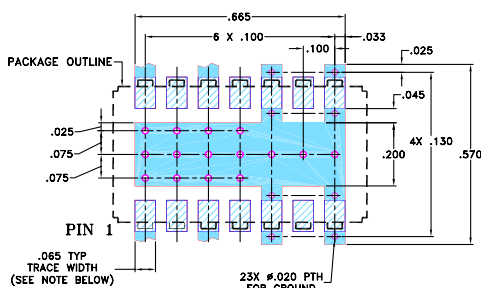

- TRACE WIDTH IS SHOWN FOR ROGERS RO4350B WITH DIELECTRIC THICKNESS .030" ± .002". COPPER: 1/2 OZ., EACH SIDE. FOR OTHER MATERIALS TRACE WIDTH MAY NEED TO BE MODIFIED.
- BOTTOM SIDE OF THE PCB IS CONTINUOUS GROUND PLANE.
 - Denotes PCB COPPER LAYOUT WITH SMOBC (SOLDER MASK OVER BARE COPPER)
 - Denotes COPPER LAND PATTERN FREE OF SOLDER MASK

Notes

- Performance and quality attributes and conditions not expressly stated in this specification document are intended to be excluded and do not form a part of this specification document.
- Electrical specifications and performance data contained in this specification document are based on Mini-Circuit's applicable established test performance criteria and measurement instructions.
- The parts covered by this specification document are subject to Mini-Circuit's standard limited warranty and terms and conditions (collectively, "Standard Terms"); Purchasers of this part are entitled to the rights and benefits contained therein. For a full statement of the Standard Terms and the exclusive rights and remedies thereunder, please visit Mini-Circuit's website at www.minicircuits.com/MCLStore/terms.jsp

Features

- wideband, 150 to 350 MHz
- low insertion loss, 0.5 dB typ.
- good isolation, 20 dB typ.
- aqueous washable

Applications

- VHF-TV
- IF signal processing
- modulators

Electrical Specifications

FREQ. RANGE (MHz)	ISOLATION (dB)		INSERTION LOSS (dB) Avg. of Coupled Outputs ABOVE 3 dB		PHASE UNBALANCE (Degrees)	AMPLITUDE UNBALANCE (dB)
	Typ.	Min.	Typ.	Max.	Max.	Max.
f_L - f_U						
150-350	20	13	0.5	1.0	5	1.5

Typical Performance Data

Frequency (MHz)	Total Loss ¹ (dB)		Amplitude Unbalance (dB)	Isolation (dB)	Phase Unbalance (deg.)	VSWR S	VSWR 1	VSWR 2
	S-1	S-2						
150.00	3.03	3.79	0.76	19.08	89.51	1.22	1.19	1.19
160.00	3.19	3.64	0.45	19.33	89.70	1.24	1.20	1.20
170.00	3.34	3.51	0.17	19.61	89.85	1.24	1.20	1.21
185.00	3.49	3.37	0.12	19.85	89.85	1.24	1.21	1.22
200.00	3.63	3.27	0.36	20.07	90.15	1.26	1.22	1.22
215.00	3.71	3.20	0.50	20.34	89.84	1.24	1.23	1.23
230.00	3.77	3.19	0.58	20.81	89.96	1.27	1.24	1.23
245.00	3.80	3.18	0.61	21.19	89.86	1.25	1.25	1.23
260.00	3.75	3.21	0.54	21.49	89.84	1.26	1.25	1.22
275.00	3.75	3.28	0.47	21.90	89.63	1.24	1.25	1.22
290.00	3.65	3.34	0.31	22.73	89.53	1.24	1.24	1.22
310.00	3.54	3.49	0.05	24.81	89.09	1.22	1.22	1.20
330.00	3.34	3.64	0.30	27.48	88.88	1.20	1.21	1.18
340.00	3.29	3.78	0.49	29.15	88.73	1.19	1.19	1.17
350.00	3.17	3.88	0.72	31.08	88.52	1.16	1.18	1.17

1. Total Loss = Insertion Loss + 3dB splitter loss.

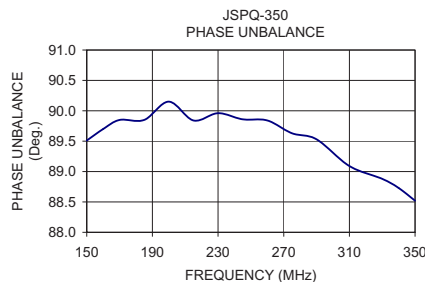
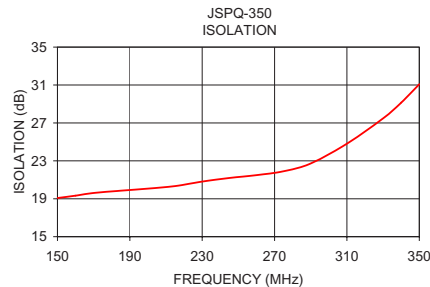
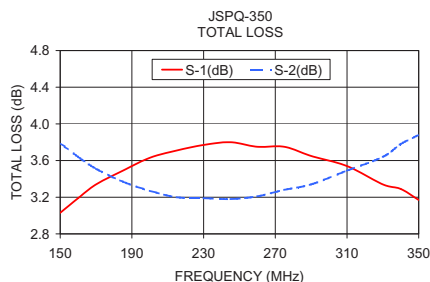

electrical schematic

