

Features

- 22 dB Gain at 900 MHz
- 22 dBm P1dB
- 40.5 dBm Output IP3
- 2.3 dB NF
- MTTF > 100 Years
- Single Supply

Description

The ASW320, a gain block amplifier MMIC, has a high linearity, high gain, and high efficiency over a wide range of frequency, being suitable for use in both receiver and transmitter of telecommunication systems up to 3 GHz. It has an active bias network for stable current over temperature and process variation. The amplifier is available in a SOT89 package and passes through the stringent DC, RF, and reliability tests



Package Style: SOT89

Typical Performance

(Supply Voltage = Device Voltage, $T_A = +25\text{ }^\circ\text{C}$, $Z_0 = 50\ \Omega$)

Parameters	Units	Typical					
		350	870	900	1600	900	1600
Frequency	MHz						
Gain	dB	23.0	22.0	22.0	19.5	22.0	19.5
S11	dB	-12	-12	-9	-7	-9	-7
S22	dB	-10	-9	-8	-6	-8	-6
Output IP3 ¹⁾	dBm	41.5	41.5	40.5	39.0	42.5	41.0
Noise Figure	dB	2.6	2.6	2.3	2.6	2.4	2.7
Output P1dB	dBm	26	26	22	21	24	23
Supply Voltage	mA	7.4	7.4	5.0	5.0	6.0	6.0
Current	V	+148	+148	+120	+120	+145	+145

1) OIP3 is measured with two tones at an output power of +10 dBm/tone separated by 1 MHz.

Applications Circuit

- 350 ~ 870 MHz (7.4 V)
- 900 ~ 1600 MHz (5 V & 6 V)
- 30 ~ 600 MHz (8 V)

Product Specifications

Parameters	Units	Min	Typ.	Max
Testing Frequency	MHz		900	
Gain	dB		22.0	
S11	dB		-9	
S22	dB		-8	
Output IP3	dBm		40.5	
Noise Figure	dB		2.3	
Output P1dB	dBm		22	
Current	mA		120	
Supply Voltage	V		+5	

Absolute Maximum Ratings

Parameters	Rating
Operating Case Temperature	-40 to +85 °C
Storage Temperature	-40 to +150 °C
Device Voltage	+8.5 V
Operating Junction Temperature	+150 °C
Input RF Power (Continuous)*	+22 dBm
Thermal Resistance	43 °C/W

* Please find the max. input power data from http://www.asb.co.kr/pdf/Maximum_Input_Power_Analysis.pdf

Pin Configuration

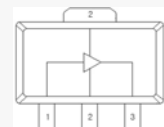

Pin No.	Function
1	RF IN
2	GND
3	RF OUT & Bias

Outline Drawing

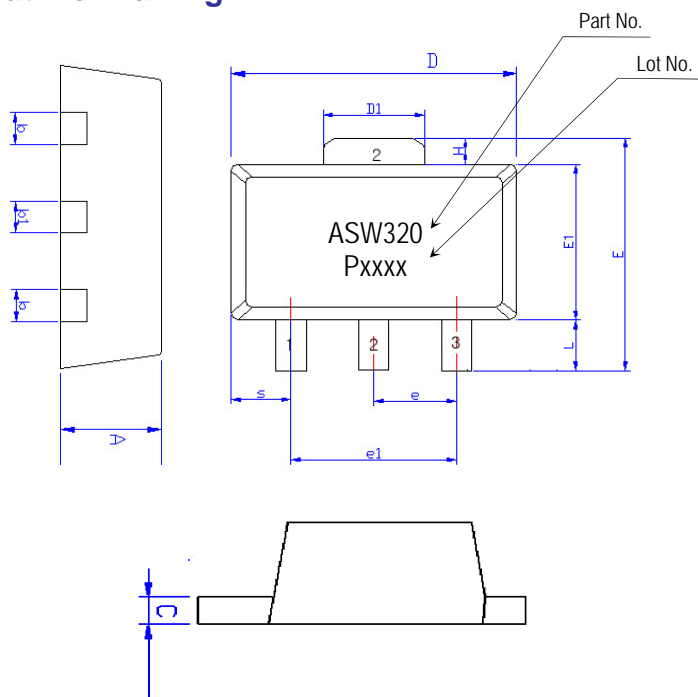

Symbols	Dimensions (In mm)		
	MIN	NOM	MAX
A	1.40	1.50	1.60
L	0.89	1.04	1.20
b	0.36	0.42	0.48
b1	0.41	0.47	0.53
C	0.38	0.40	0.43
D	4.40	4.50	4.60
D1	1.40	1.60	1.75
E	3.64	---	4.25
E1	2.40	2.50	2.60
e1	2.90	3.00	3.10
H	0.35	0.40	0.45
S	0.65	0.75	0.85
e	1.40	1.50	1.60

Pin No.	Function
1	RF IN
2	GND
3	RF OUT & Bias

Mounting Recommendation (In mm)

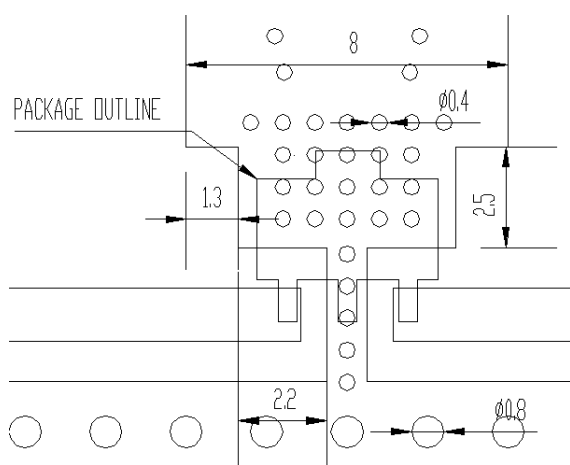

- Note:**
1. The number and size of ground via holes in a circuit board is critical for thermal and RF grounding considerations.
 2. We recommend that the ground via holes be placed on the bottom of the lead pin 2 and exposed pad of the device for better RF and thermal performance, as shown in the drawing at the left side.

ESD Classification & Moisture Sensitivity Level

ESD Classification

HBM	Class 1B
	Voltage Level: 550 V
MM	Class A
	Voltage Level: 50 V

CAUTION: ESD-sensitive device!

Moisture Sensitivity Level (MSL)

Level 3 at 260 °C reflow

APPLICATION CIRCUIT

DVB & CMMB

350 ~ 870 MHz

+7.4 V

Frequency (MHz)	350	870
Magnitude S21 (dB)	23.0	22.0
Magnitude S11 (dB)	-12	-12
Magnitude S22 (dB)	-10	-9
Output P1dB (dBm)	26	26
Output IP3 ¹⁾ (dBm)	41.5	41.5
Noise Figure (dB)	2.6	2.6
Device Voltage (V)	+7.4	+7.4
Current (mA)	148	148

1) OIP3 is measured with two tones at an output power of +12 dBm/tone separated by 1 MHz.

Schematic

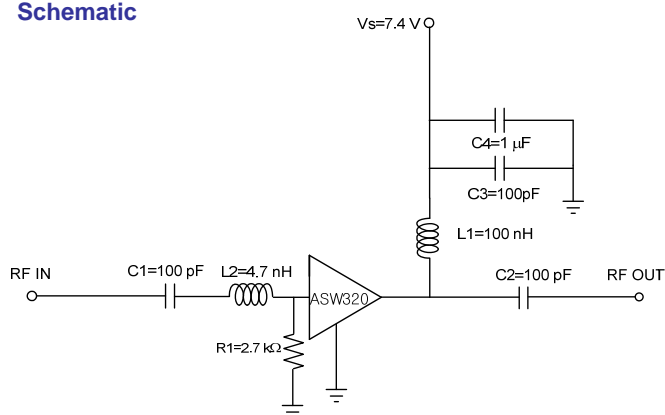

Board Layout (FR4, 40x40 mm², 0.8T)

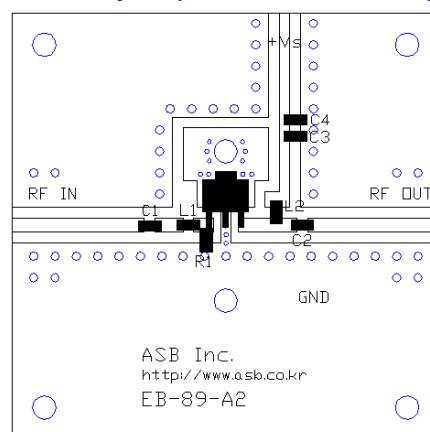

S-parameters & K-factor

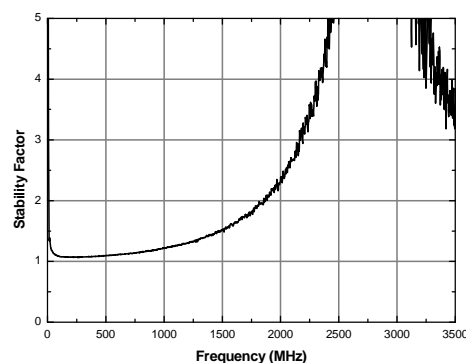
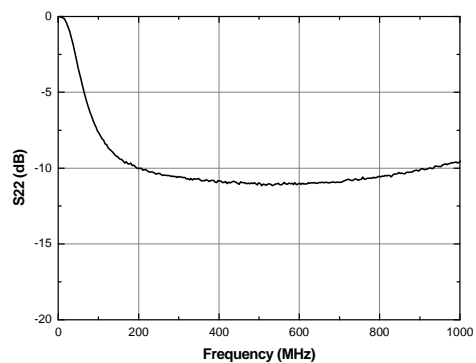
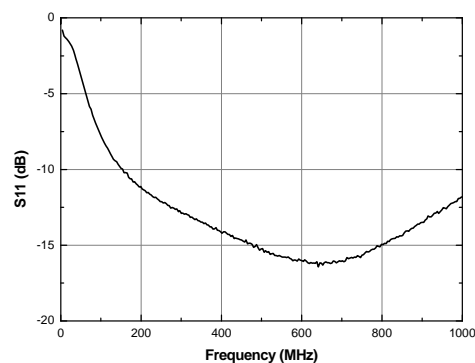
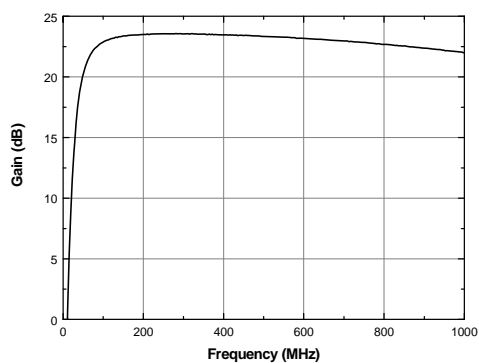

APPLICATION CIRCUIT

MoCA

900 ~ 1600 MHz

+5 V & +6 V

Frequency (MHz)	900	1600	900	1600
Magnitude S21 (dB)	22.0	19.5	22.0	19.5
Magnitude S11 (dB)	-9	-7	-9	-7
Magnitude S22 (dB)	-8	-6	-8	-6
Output P1dB (dBm)	22	21	24	23
Output IP3 ¹⁾ (dBm)	40.5	39.0	42.5	41.0
Noise Figure (dB)	2.3	2.6	2.4	2.7
Device Voltage (V)	+5	+5	+6	+6
Current (mA)	120	120	145	145

1) OIP3 is measured with two tones at an output power of +10 dBm/tone @ 5 V, +12dBm/tone @ 6 V separated by 1MHz.

Schematic

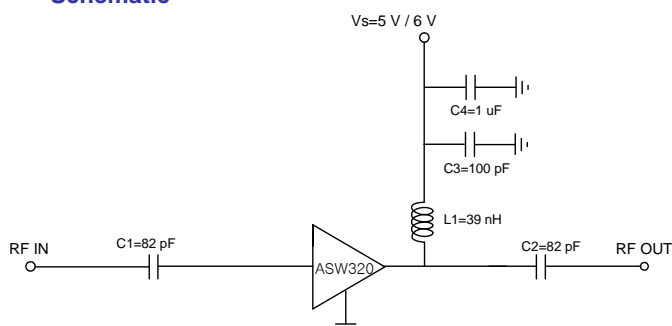

Board Layout (FR4, 40x40 mm², 0.8T)

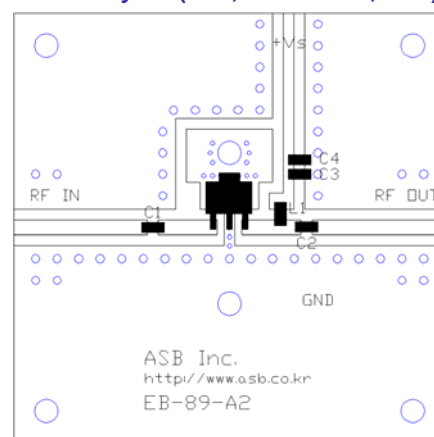

S-parameters & K-factor

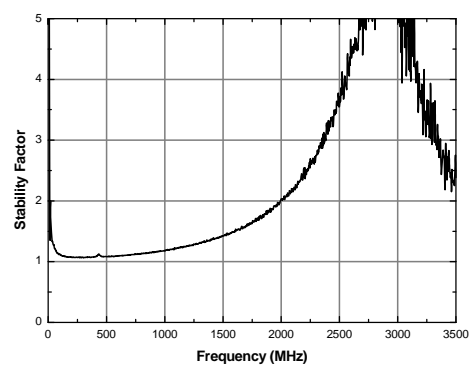
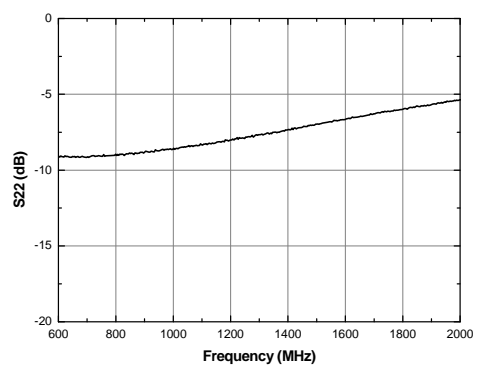
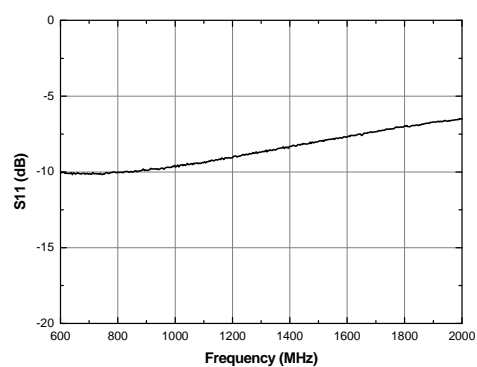
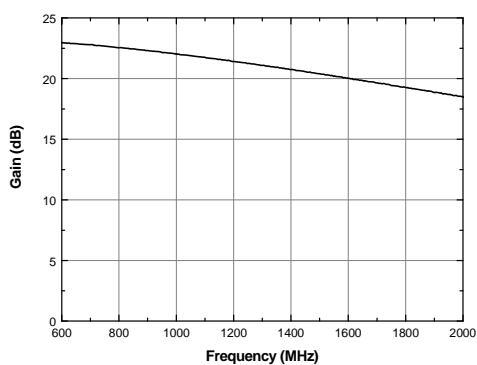

APPLICATION CIRCUIT

IF
 30 ~ 600 MHz
 +8 V

Frequency (MHz)	30	600
Magnitude S21 (dB)	23.0	22.7
Magnitude S11 (dB)	-10	-16
Magnitude S22 (dB)	-9	-10
Output P1dB (dBm)	26	26
Output IP3 ¹⁾ (dBm)	40.0	39.5
Noise Figure (dB)	2.6	2.6
Device Voltage (V)	+8	+8
Current (mA)	135	135

1) OIP3 is measured with two tones at an output power of +7 dBm/tone separated by 1 MHz.

Schematic

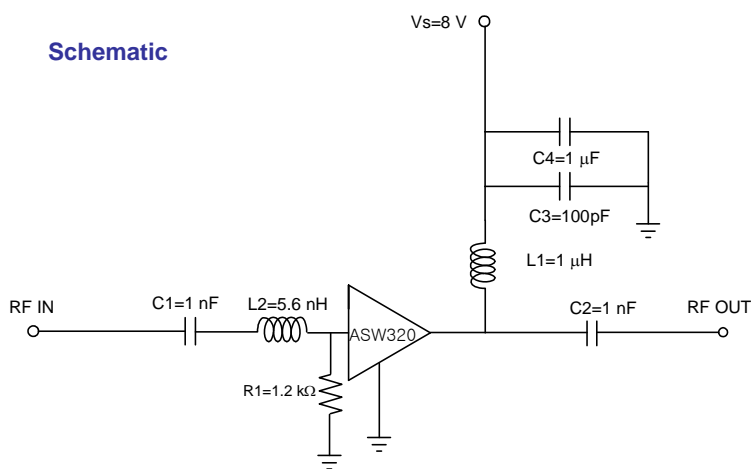

Board Layout (FR4, 40x40 mm², 0.8T)

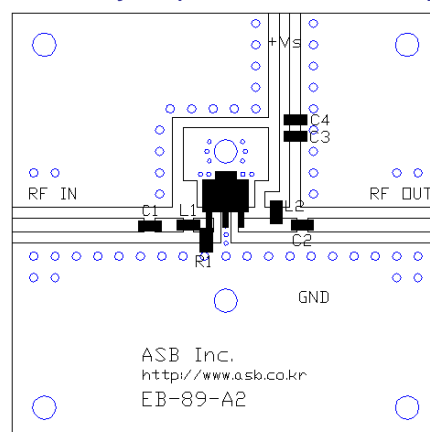

S-parameters & K-factor

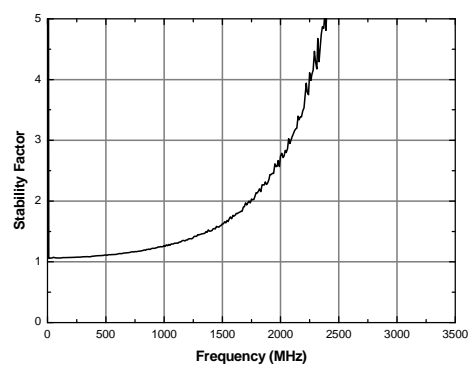
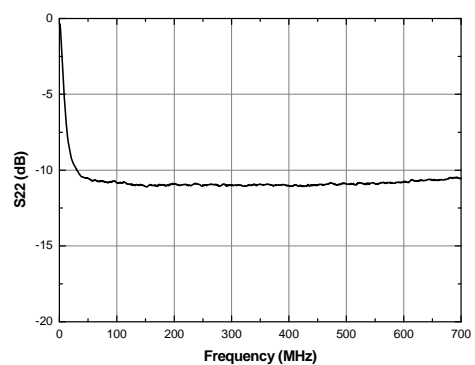
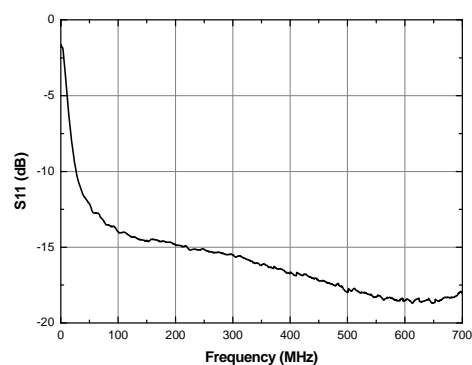
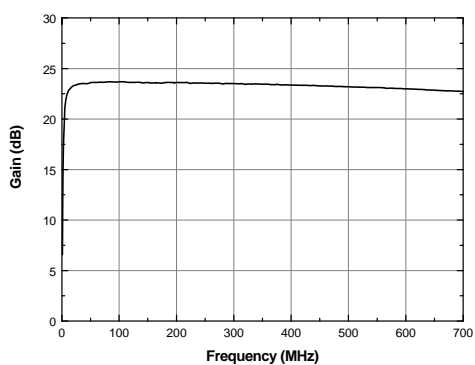

Recommended Soldering Reflow Profile

