

Helping Customers Innovate, Improve & Grow

EX-420

Description

The EX-420 provides exceptionally low aging rates and tight temperature stabilities in an extremely small package over a wide range of environmental conditions. This EMXO series bridges the gap between current large, high precision OCXO's and smaller TCXO's. The EX-420 Series becomes the most economical choice where there is a need for spectral purity, short and long term stability, along with small size and dramatically reduced power consumption.

Features

- 4-Pin Half Dip
- Fast Warmup
- Low Power Consumption
- Previous Model Number: EX-620 series
- Frequency Range: 10 MHz - 30 MHz

Applications

- SONET/SDH, DWDM, FDM, ATM, 3G
- Telecom Transmission and Switching Equipment
- Wireless Communication Equipment
- Military Airborne and Mobile systems

Performance Specifications

Parameter	Frequency Stabilities ¹				Condition
	Min	Typ	Max	Units	
vs. operating temperature range (referenced to +25°C)	-50		+50	ppb	0... +70°C
	-75		+75	ppb	-20... +70°C
	-100		+100	ppb	-40... +85°C

Performance Specifications

Frequency Stabilities ¹						
Parameter		Min	Typ	Max	Units	Condition
vs. Stratum 3 per GR-1244- CORE	Operating Temp	-140		+140	ppb	-20... +70°C
		-140		+140	ppb	-40... +85°C
	Holdover	-370		+370	ppb	24 hours
	Drift	-4.63		+4.63	ppb	Over 7100 seconds
	MTIE			+1	10-13/sec ppm	0.16 sec < Observe Times < 64 sec
Warm-up Time				1 1.5	minutes minutes	to ± 100 ppb of final frequency (1 hour) @+25°C to ± 100ppb of final frequency (1 hour) @-40°C
Initial Accuracy		-1		+1	ppm	fixed frequency, no EFC input VS ± 5% Load ± 5% after 30 days of operation after 30 days of operation
vs. supply voltage change		-20		+20	ppb	
vs. load change		-10		+10	ppb	
vs. aging / day		-2.0		+2.0	ppb	
vs. aging / 1 year		-300		+300	ppb	
Supply Voltage (Vs)						
Supply voltage (Standard)		4.75	5.0	5.25	VDC	
Supply voltage (Option)		3.135	3.3	3.465	VDC	
Power Consumption				1.5 0.3 0.6	Watts Watts Watts	during warm-up steady state @ +25°C steady state @ -40°C
RF Output						
Signal [Standard]		HCMOS				
Load			15		pF	
Signal Level (Vol)				0.1	VDC	
Signal Level (Voh)		0.8			VDC	
Duty cycle		40		60	%	(Voh-Vol)/2
Signal [Standard]		Sinewave				
Load			50		ohm	
Output Power [Standard]		0		+4	dBm	50 Ohm load
Output Power [Option]		+3		+7	dBm	50 Ohm load
Harmonics				-30	dBc	50 Ohm load
Spurs				-60	dBc	50 Ohm load
Frequency Tuning (EFC) 10 to 80 MHz						
Tuning Range		Fixed EMXO; No adjust				
Tuning Range		±3.0		±10.0	ppm	from 0V to Vs
Linearity				20	%	
Tuning Slope		Positive				
Additional Parameters						
Phase Noise				-100 -130 -140 -145	dBc/Hz dBc/Hz dBc/Hz dBc/Hz	10 Hz 100 Hz 1 KHz 10 KHz
Allan Deviation				0.2	ppb	Tau = 1 sec to 10 sec
Weight				3	g	
Processing & Packing		Handling & processing note				
Absolute Maximum Ratings						
Supply Voltage				5.5	VDC	
Output Load				30	pF	

Frequency Stabilities¹

Parameter	Min	Typ	Max	Units	Condition
Operable temperature range	-55		+85	°C	
Storage temperature range	-55		+85	°C	

Environmental Conditions

• Mechanical Shock (survive)	MIL-STD-202, Test Method 213, Condition E (100G, 0.5msec)
• Vibration Random (survive)	MIL-STD-202, Test Method 214, Condition I-H (20Grms, 3 minutes/axis)
• Vibration Sine (survive)	MIL-STD-202, Test Method 204, Condition D (20Grms, 20 minutes/axis)
• Thermal Shock (survive)	MIL-STD-202, Test Method 107, Condition A-2 (50 Cycles, -55°C to +85 °C)

Outline Drawing / Enclosure

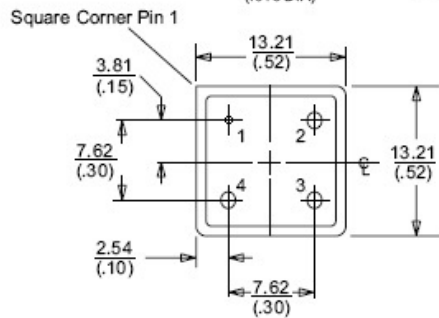
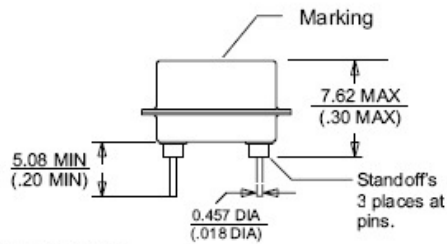

Type A

mm
(in.)

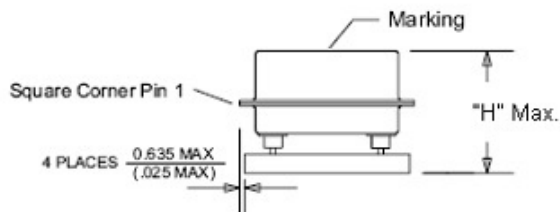

Type B

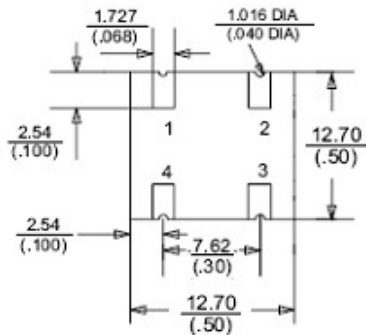

mm
(in.)

Dimensions in mm (inches)

Type A

Code	Height "H"	Pin Length "L"
0	7.62	5.08

Type B

Code	Height "H"	Pin Length "L"
1	8.89	NA
2	9.65	NA

Pin Connections

1	EFC \ No Connect
2	Ground (Case)
3	RF Output
4	Supply Voltage Input

Recommended Reflow Profile

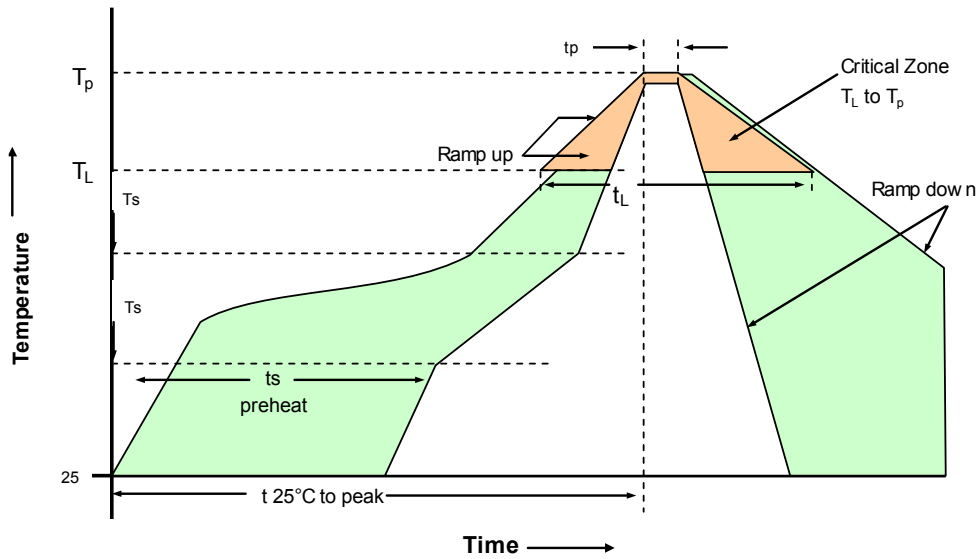

Profile Feature	Sn-Pb Assembly	Profile Feature	Sn-Pb Assembly
PRECAUTION: Series shall not expose to temperature higher than 230°C. If exposing to temperature higher than 230°C, stability and power consumption may permanently degrade.			
Average ramp-up rate (TL to Tp)	3°C/second max.	Time 25°C to Peak Temperature	4 minutes max.
Preheat - Temperature Min Tsmin) - Temperature Min Tsmax) - Time (min to max) (ts)	135°C 155°C 60-90 seconds	Time maintained above - Temperature (TL) - Time (tL)	183°C 45-60 seconds
Tsmax to TL - Ramp-up Rate	3°C/second max.		
Time maintained above - Temperature (TL) - Time (tL)	183°C 45-60 seconds	Time within 5°C of actual Peak Temperature (tp)	10-20 seconds max.
Peak Temperature (Tp)	max 220°C	Ramp-down Rate	6°C/second max.
Note: All temperatures refer to topside of the package, measured on the package body surface.			

Ordering Information

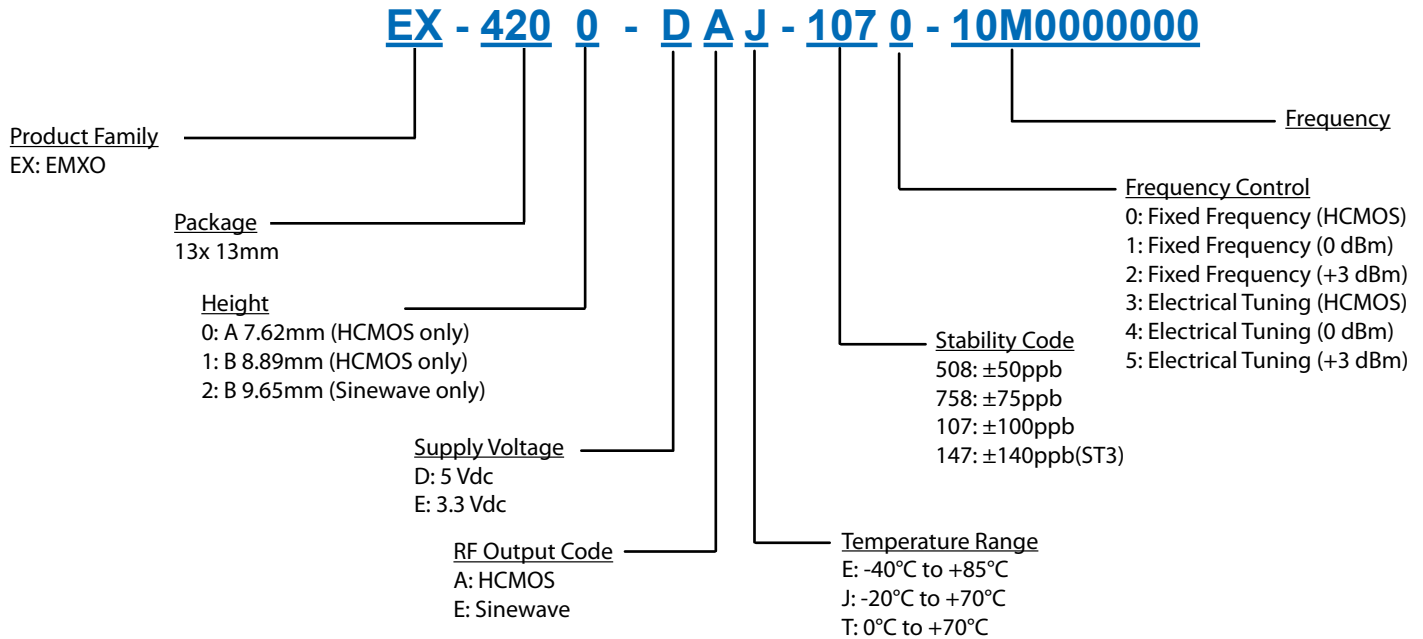

Notes:

1. Contact factory for improved stabilities or additional product options. Not all options and codes are available at all frequencies.
2. Unless other stated all values are valid after warm-up time and refer to typical conditions for supply voltage, frequency control voltage, load, temperature (25°C).
3. Phase noise degrades with increasing output frequency.
4. Subject to technical modification.
5. Contact factory for availability.

For Additional Information, Please Contact

USA:

Vectron International
267 Lowell Road, Unit 102
Hudson, NH 03051
Tel: 1.888.328.7661
Fax: 1.888.329.8328

Europe:

Vectron International
Landstrasse, D-74924
Neckarbischofsheim, Germany
Tel: +49 (0) 3328.4784.17
Fax: +49 (0) 3328.4784.30

Asia:

Vectron International
68 Yin Cheng Road(C), 22nd Floor
One LuJiaZui
Pudong, Shanghai 200120, China
Tel: 86.21.6194.6886
Fax: 86.21.6194.6699

Disclaimer

Vectron International reserves the right to make changes to the product(s) and or information contained herein without notice. No liability is assumed as a result of their use or application. No rights under any patent accompany the sale of any such product(s) or information.