

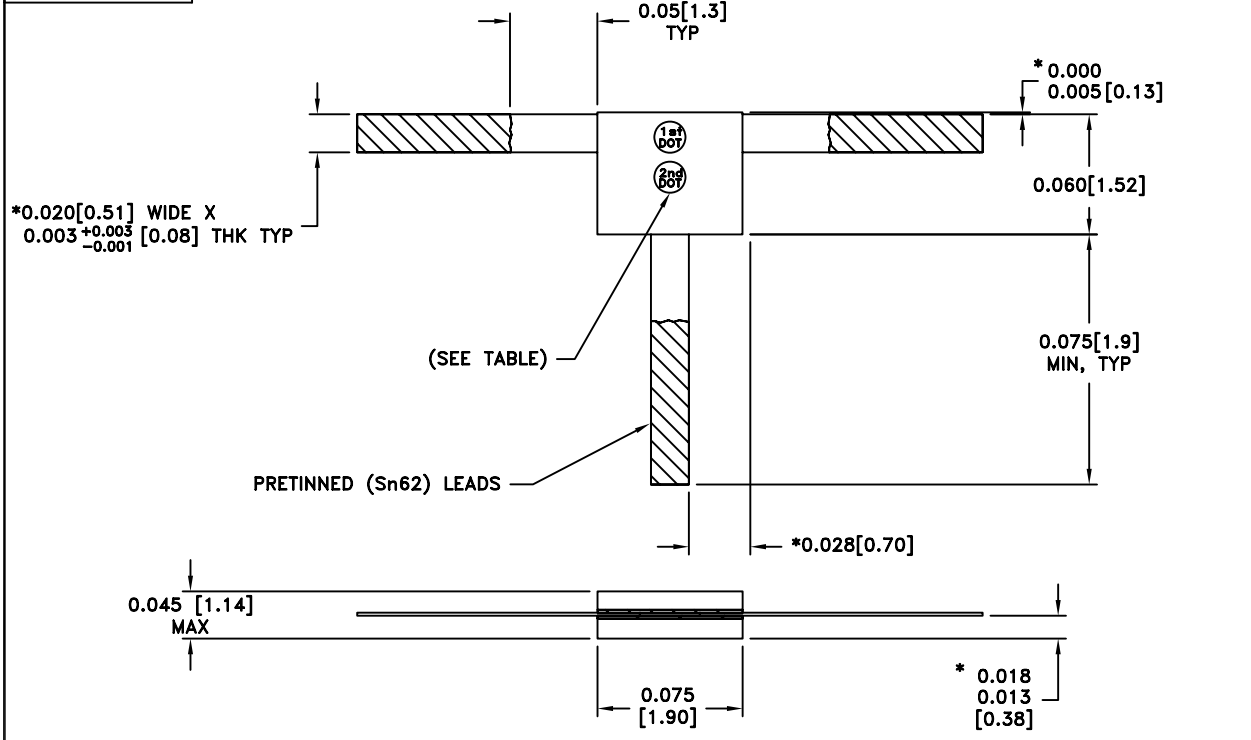

PART ID REF  
TS95XXT3S



METRIC EQUIVALENTS GIVEN IN [mm]  
FOR REFERENCE INFORMATION ONLY

**MECHANICAL SPECIFICATIONS:**

**SUBSTRATE & TOP PLATE:**  
MATERIAL - ALUMINA 96%, MIL-I-10.

**TERMINAL:**  
MATERIAL - PLATINUM GOLD.

**RESISTIVE ELEMENT:**  
MATERIAL - TANTALUM NITRIDE.

**LEAD:**  
MATERIAL - COPPER, ASTM B152.  
FINISH: GOLD, MIL-G-45204, TYPE II, CLASS 1.

**SOLDER:**  
MATERIAL - Sn62, QQ-S-571.

ALLOW +/-0.010 ON TOP PLATE FOR MISALIGNMENT

\* DIMENSIONS APPLY BEFORE SOLDER. ALLOW 0.015 MAX FOR ALL PRETINNED SURFACES.

REFERENCE TABLE					
dB VAL	DOT COLOR		dB VAL	DOT COLOR	
	1st	2nd		1st	2nd
0	BLK	---	11	BRN	BRN
1	BRN	---	12	BRN	RED
2	RED	---	13	BRN	ORG
3	ORG	---	14	BRN	YEL
4	YEL	---	15	BRN	GRN
5	GRN	---	16	BRN	BLU
6	BLU	---	17	BRN	VIO
7	VIO	---	18	BRN	GRY
8	GRY	---	19	BRN	WHT
9	WHT	---	20	RED	BLK
10	BRN	BLK			

**POWER RATING AND DERATING**

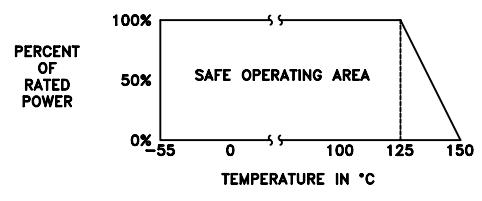

**EMC Technology**  
8851 SW OLD KANSAS AVE  
STUART, FL 34997  
PHONE NO. (772)286-9300  
FAX NO. (772)283-5286

UNLESS OTHERWISE SPECIFIED DIMENSIONS ARE IN INCHES  
**TOLERANCES**  
FRACT --- ---  
ANG --- ---  
XX ±0.02  
XXX ±0.005  
XXXX --- ---

THESE DRAWINGS AND SPECIFICATIONS ARE THE PROPERTY OF EMC TECHNOLOGY INC AND SHALL NOT BE DUPLICATED OR USED AS BASIS FOR THE MANUFACTURE OR SALE OF PARTS OR DEVICES WITHOUT PERMISSION.

CAGE CODE <b>24602</b>	SCALE <b>1:1</b>	DRAWN BY <b>JG 3/16/10</b>	CHECKED BY	APPROVED BY
REV <b>D</b>	CHANGE NOTICE <b>EN 10-E0406</b>	DRAWING NO <b>1001095000</b>	SHEET <b>2 OF 2</b>	