



## C Male Connector Clamp/Solder Attachment For RG58, RG55, RG141, RG142, RG223, RG400

### TECHNICAL DATA SHEET

PE4242

#### C Male Connector Clamp/Solder Attachment For RG58, RG55, RG141, RG142, RG223, RG400

##### Configuration

Connector	C Male
Connector Interface Type	RG58, RG55, RG141, RG142, RG223, RG400
Cable Attachment Method (Shield/Contact)	Clamp/Solder
Body Style	Straight

##### Electrical Specifications

Impedance, Ohms	50
-----------------	----

##### Mechanical Specifications

###### Size

Length, in [mm]	1.4 [35.56]
Width/Dia., in [mm]	0.75 [19]
Weight, lbs [g]	0.082 [37.19]

###### Connector

Type	C Male
Contact Material and Plating	Silver
Coupling Nut Material and Plating	Nickel
Body Material and Plating	Nickel
Dielectric Type	PTFE

##### Compliance Certifications (visit [www.Pasternack.com](http://www.Pasternack.com) for current document)

RoHS Compliant	Yes
----------------	-----

##### Plotted and Other Data

Notes:	Values at 25 °C, sea level
--------	----------------------------

URL: <http://www.pasternack.com/c-male-standard-rg58-rg55-rg141-rg142-rg223-rg400-connector-pe4242-p.aspx>

C Male Connector Clamp/Solder Attachment For RG58, RG55, RG141, RG142, RG223, RG400 from Pasternack Enterprises has same day shipment for domestic and International orders. We maintain 99% availability of the industry's broadest selection of RF, microwave and fiber optic products.

The information contained in this document is accurate to the best of our knowledge and representative of the part described herein. It may be necessary to make modifications to the part and/or the documentation of the part, in order to implement improvements. Pasternack reserves the right to make such changes as required. Unless otherwise stated, all specifications are nominal.

# PE4242 CAD Drawing

C Male Connector Clamp/Solder Attachment For RG58,  
RG55, RG141, RG142, RG223, RG400

## ASSEMBLY PROCEDURES

1. SLIDE CLAMP NUT (1), WASHER (2) & GASKET (3) OVER CABLE. STRIP CABLE AS SHOWN. DO NOT NICK BRAID WHILE CUTTING JACKET. TAPER END OF BRAID TO PERMIT ASSEMBLY OF BRAID CLAMP (4). SLIDE BRAID CLAMP (4) OVER BRAID & SEAT AGAINST CABLE.

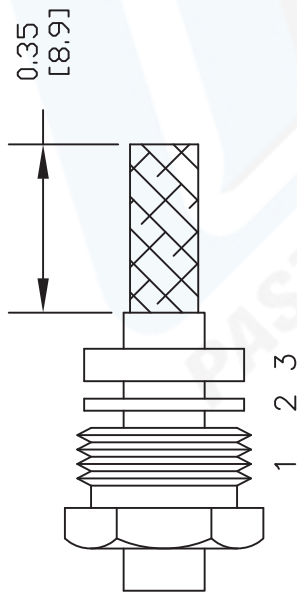

2. FORM BRAID OVER CLAMP NUT (4). TRIM BRAID BACK TO SHOULDER. CUT DIELECTRIC & CENTER CONDUCTOR TO DIMENSION SHOWN. DO NOT NICK CENTER CONDUCTOR. SOLDER CONTACT TO CENTER CONDUCTOR. REMOVE EXCESS SOLDER. DO NOT OVER HEAT DIELECTRIC. INSERT CABLE ASSEMBLY INTO BODY & TIGHTEN.

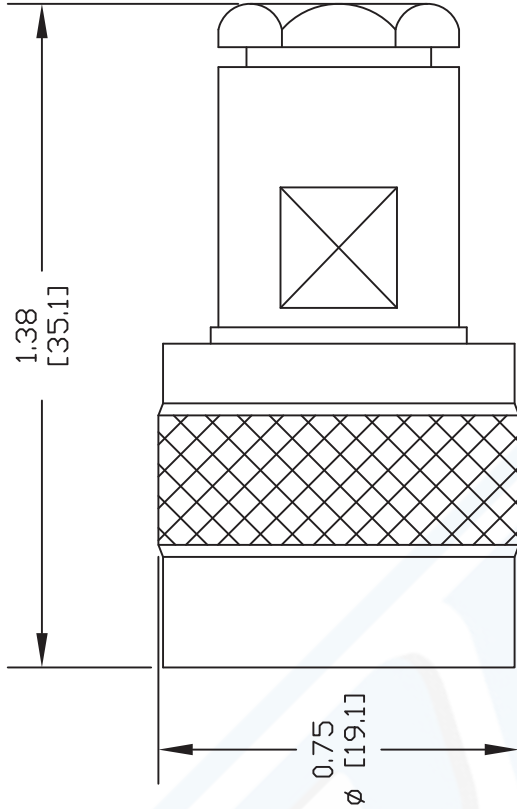
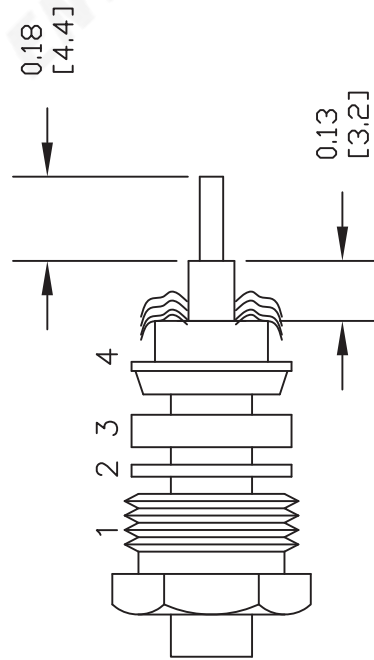

DWG TITLE

**PE4242**

NOTES:  
1. UNLESS OTHERWISE SPECIFIED ALL DIMENSIONS ARE NOMINAL.  
2. ALL SPECIFICATIONS ARE SUBJECT TO CHANGE WITHOUT NOTICE AT ANY TIME.  
3. DIMENSIONS ARE IN INCHES [mm].  
4. FITS MIL-C-17 AND EQUIVALENT CABLES.

**PASTERNAK®**  
Pasternack Enterprises, Inc.  
P.O. Box 16759 | Irvine | CA | 92623  
Phone: (949) 261-1920 | Fax: (949) 261-7451  
Website: www.pasternack.com | E-Mail: sales@pasternack.com

FSCM NO. 53919

CAD FILE 042309

SCALE N/A

SIZE A

147